

# Lets Talk About Tool Integration and Interoperability

What Is The Big Deal, What Are The  
Issues and What Are We Doing About  
It?

# *Technology Enablers Sector*

**Autonomous  
System Test and  
Evaluation**

**Model Driven  
System Design**

**Tools Database WG**

**Tool Integration and  
Interoperability**



## The Mission

*Foster improved productivity and quality of  
systems engineering by enabling  
processes with technology, information  
and interoperability standards.*

# *Tools Integration & Interoperability Working Group (TIIWG)*



## Our Mission

*Foster improved productivity and quality of  
systems engineering through integration  
and interoperability of tools and  
environments.*

# Integration and Interoperability

- Did you know the difference between tool integration and interoperability?
- Do you care? If not should you?
- Have you ever wondered why it seems to be so difficult to integrate software applications?
- What does it take to integrate a systems engineering environment?

**We will be discussing these questions and others during this meeting**

# First Things First

- Did you know the difference between tool integration and interoperability?

These terms are typically interchanged and used in the wrong context. So.....

# Integration vs Interoperability

- **Integration is:**

the capability of tools to communicate, share data and present information to users in a coherent fashion.

- **Integrated Environment :**

- all components functioning as part of a single, consistent, coherent whole, sharing data, presenting data and communicating with minimal user intervention.
- Integration is delineated into five elements:

**Presentation, Data, Communication,  
Control, and Process**

# Integration Issues

- Tool **integration** is required when information needs to be moved or shared between two or more tools. SOME Problems with data exchange between tools include:
  - Tools address different technical or business domains (language of the domain, organization, nation.... Ontology, taxonomy)
  - Tools address different life cycle phases (discovery, architecture, analysis, planning , design, manufacturing, supply chain...)
  - Tools in the same domain utilize different methodologies and notational languages (e.g., relational versus object oriented data, six sigma, UML, SysML, BPMN, IDEF.....)
  - Tool vendors lack interfaces to all the tools you need in your product development environment for an entire life cycle.

# Integration vs Interoperability

- **Interoperability is:**

- a.) The ability of two or more tools to exchange information and to exchange data and to be able to **operate** on the information that has been exchanged.
- c.) The ability to share information between tools via common exchange mechanisms. (ISO 10303-AP239,233; XMI; XML)
- b.) The ability of a tool or tools to work with other tools without a special effort from the user.

# Interoperability Issues

- System data has to be exchanged between system life cycle process stages – different taxonomy, processes and formats
- There is a need to share system knowledge between multiple organizations developing the system
- Passing product data from discipline to discipline or one organization to another
- And when there is a data exchange required between tools being used to support the systems engineering processes feeding multiple engineering disciplines, management, manufacturing, etc.

# Issues Review: Some of The Big Ones

- Tools address different technical domains
- Tools address different life cycle phases (discovery, architecture, analysis, planning, design, manufacturing, ...). This is an integration issue as well, but on a much larger scale.
- Tools in the same domain utilize different methodologies (e.g., relational vice object oriented data, six sigma, UML, SySML, BPMN.....)
- Tool vendors lack interfaces to all the tools you need in your product development environment for an entire life cycle.

# ISSUES: The Real Big Ones

- Semantic interoperability or exchange
- Preservation of syntax (phraseology, attributes, ...)
- Preservation of semantics (meaning of terms & methodology)
- Preservation of format (visual appearance)
- Preservation of control (configuration management, ownership)
- Preservation of relationships (associations between data items)
- Preservation of security (levels, markings, access, ITAR)

# The REALLY BIG ISSUE- HIL

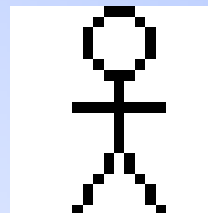
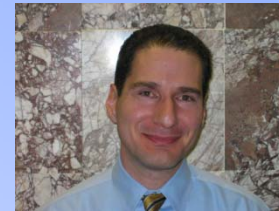
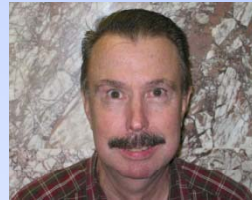
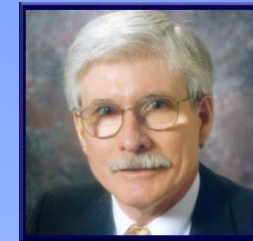

# What Do They Want?

- Everything to be USER FRIENDLY
- and INTUITIVE
- EASY TO LEARN ( this means no training)
- Support MY process but you develop it in your tool
- Move information seamlessly so I don't have to do anything
- Automation of repetitive tasks
- It all OOTB with one install wizard and no IT support.

# and WE

- Don't read the manuals
- Twitter or Facebook during training classes
- Generate SEMANTIC BYPASS
- Never attend all days of training
- Would rather ask our nearest friend for help
- Are too busy to learn the processes

The HIL is the Best Issue Generator

# What is Being Done?

- INCOSE is heavily engaged in process, integration and interoperability standards development and maintenance
  - ISO, OMG, IEC, IEEE, etc.
- The ***Model Based Systems Engineering Initiative*** was established to promote the use of the processes and standards by government, industry, academia and tool vendors on co-operative teams.
  - Proving grounds for standards
  - Experiment grounds for new processes and methods
  - Learning environment for all.
  - Published results at the Workshops and Symposiums

**All Technical Operations Working Group activities have been aligned to the INCOSE 2020 and supporting MBSE**

# What is Being Done?

- A Technical Operations OUTREACH effort is underway to the Local Chapters to encourage more projects and contributions to the MBSE Initiative. (I can recommend a chapter meeting speaker to review the activities of the WGs)
  - There are many issues to solve, many WGs are taking them on, but there are many that can be worked by Local Chapters as well.
  - For Example: The Colorado Chapter is engaged in an MBSE project on collaboration, interoperability and management of system models by a multiple company, with a dispersed team.

# What is Being Done?

- The MBSE Challenge Teams, Tool Integration and Interoperability WG and Tools Db WG have been addressing the integration and interoperability issues – we do not have all the answers.
- INCOSE in co-operation with ISO/OMG and DoD/NII has resulted in ISO 10303-AP233, SysML, UPDM standards coming to fruition.
- Tools Db is synchronized with new requirements, functions, processes and taxonomy.

# ISO/IEC 15288 View of the World

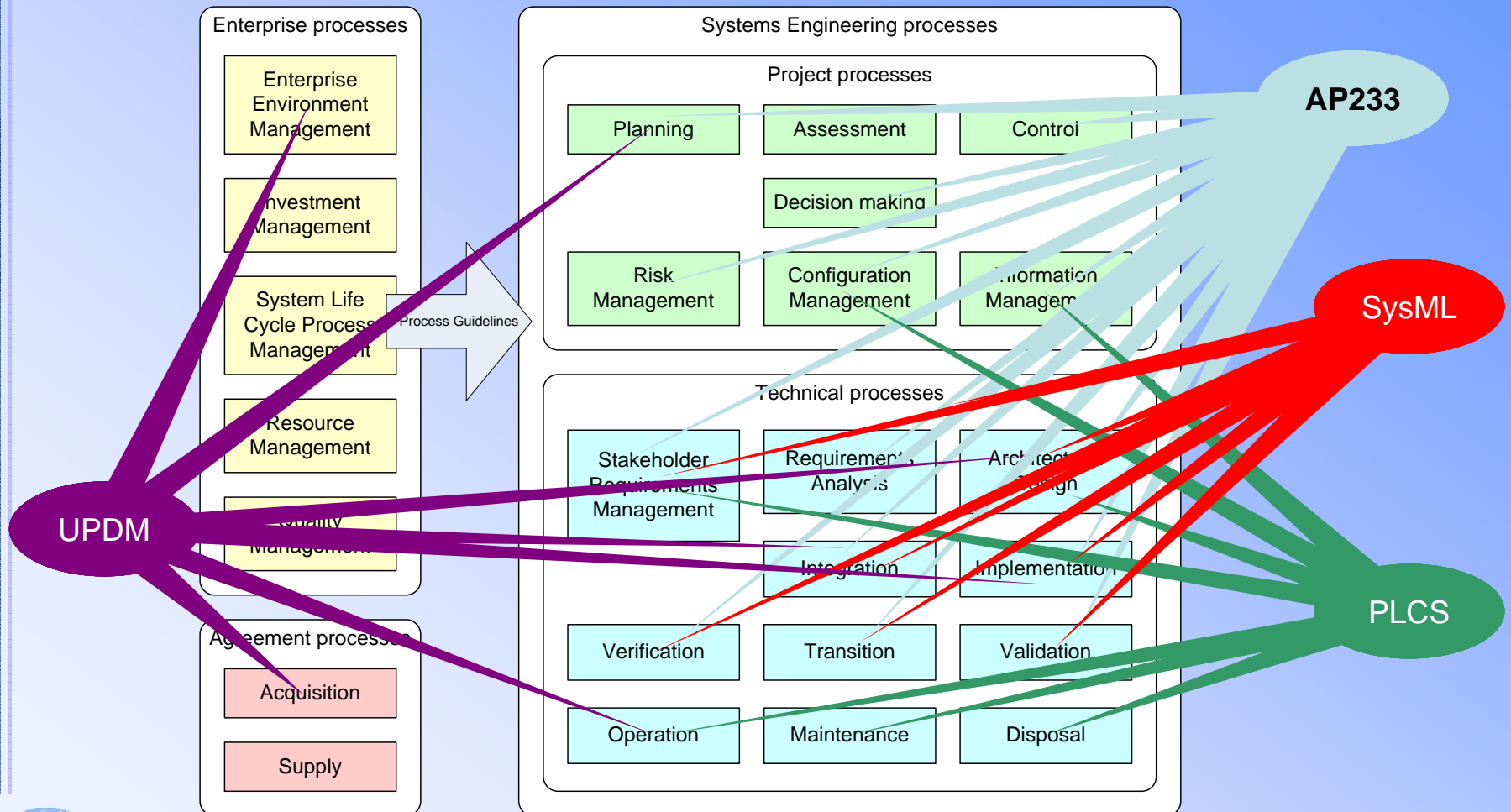

# AP233 enables

- ... communication between similar tools in Systems engineering usage
- ... communication between different tools both within and external to Systems engineering functions
- ... holistic approaches to data sharing
- ... fine grain configuration management to Systems engineering data
- ... sharing of management data currently locked up in proprietary formats and tools

# AP233 Leverages Other Standards

- AP233 links to 30+ other ISO STEP information model standards (called Application Protocols)
  - Configuration Controlled Design (AP203)
  - Engineering Analysis (AP209 E2)
  - Produce Lifecycle Support (AP239/PLCS)
- AP233 and OMG SysML are aligned
  - AP233 and SysML were developed by the same INCOSE team (MDSD/TIIWG) and share many concepts

# STEP for DOD Acquisition Cycle

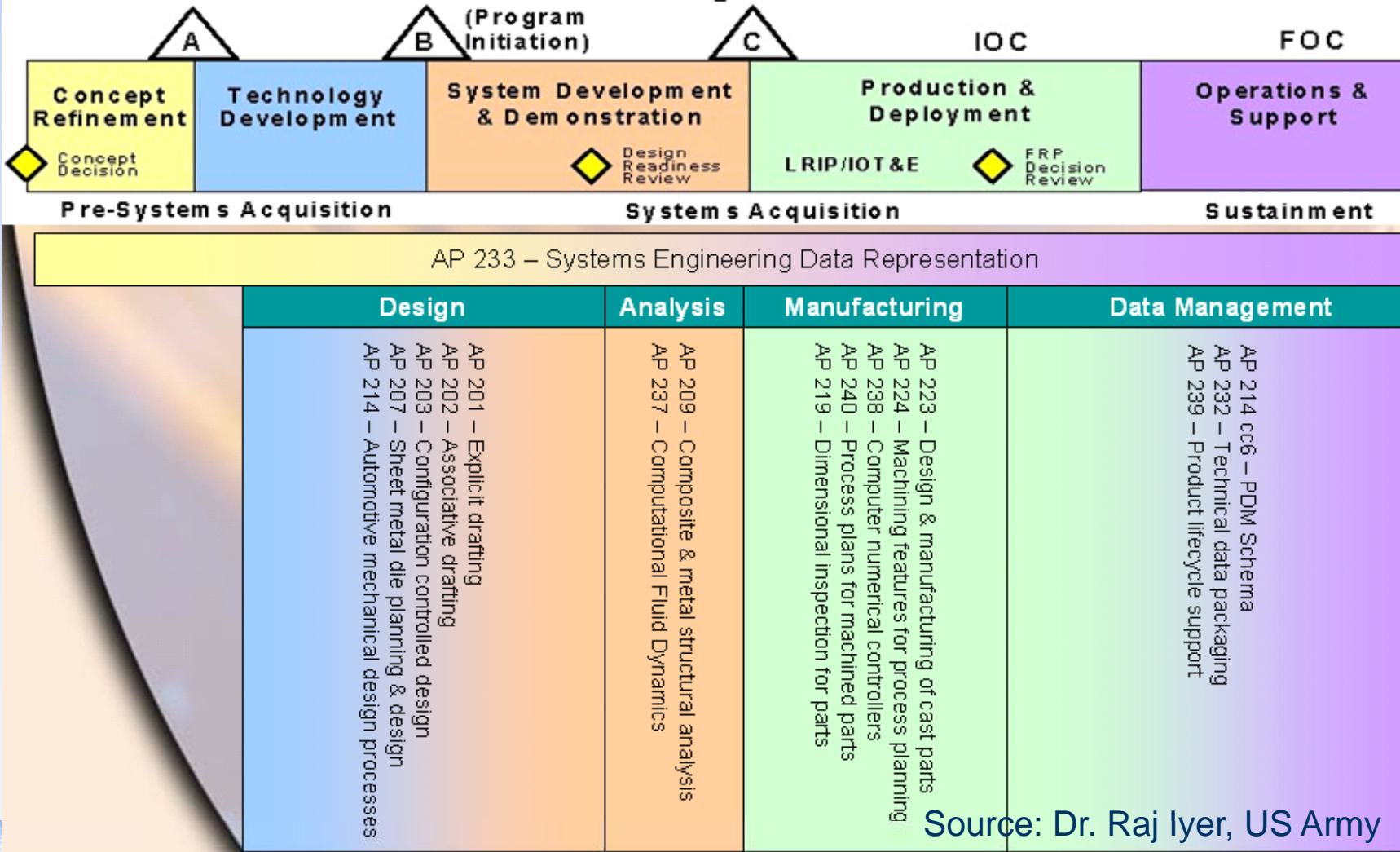

Source: Dr. Raj Iyer, US Army

# Model Based Collaborative design process

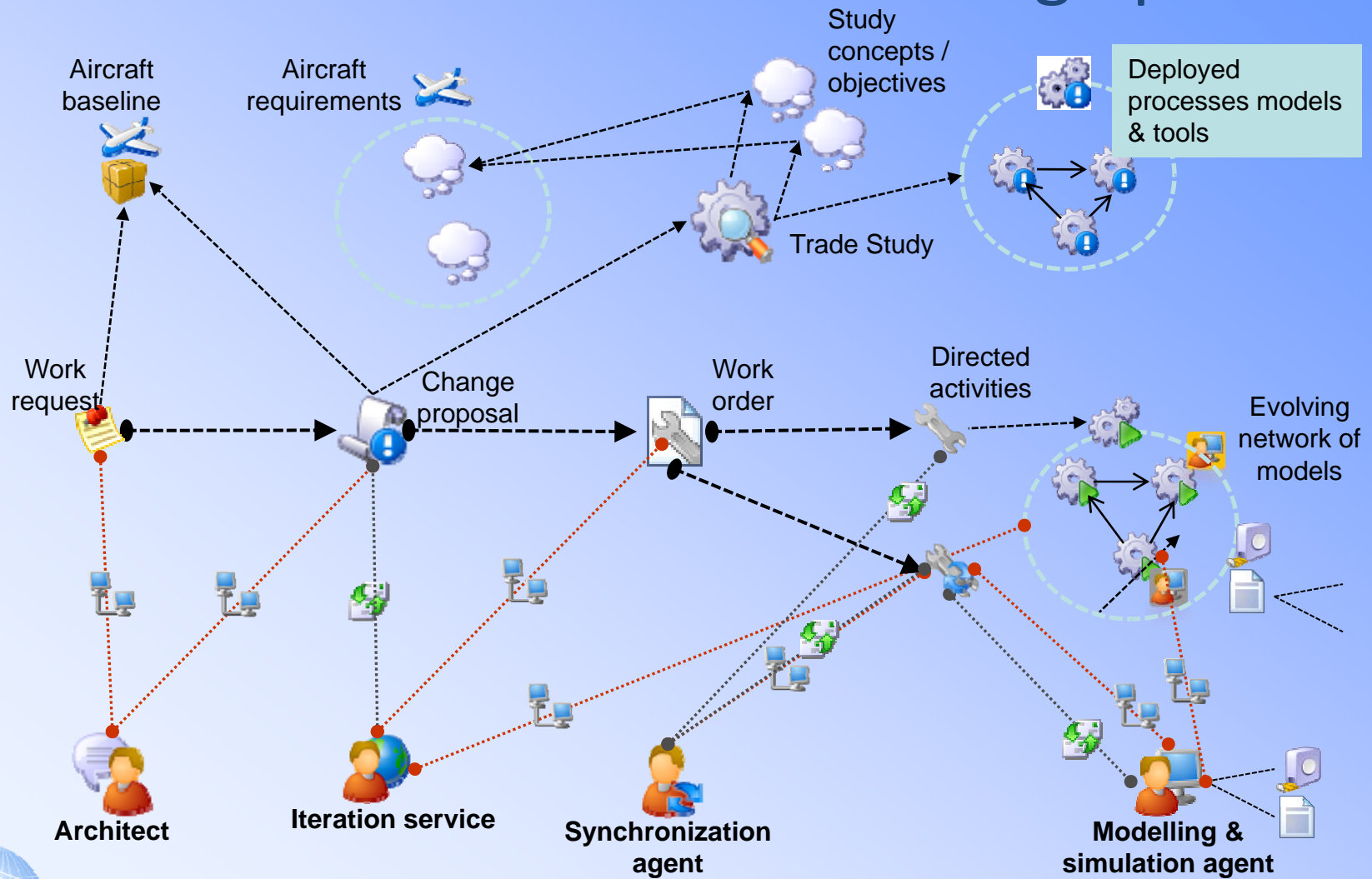

# NIST Project Summary

- Significant progress
  - on formal mapping of SysML and AP233
  - in harvesting AP233 into “OMG MDA environment”
    - OMG standard for ISO EXPRESS language
    - The *Validator!*
- Still to do
  - AP233 Change Management of SysML
  - Systems Engineering Services
  - AP233 Ontology work

# Communications

- [wiki.omg.org](http://wiki.omg.org)
  - SysML Portal
    - SysML-AP233 Mapping area
  - [sysml-ap233@omg.org](mailto:sysml-ap233@omg.org) Email list
- OMG Model Interchange team supporting NIST SE Plug-Fest
- TIIWG Connect site has lots of AP233-related information (e.g. usage scenarios)
- [www.ap233.org](http://www.ap233.org)

# Questions You May Have?

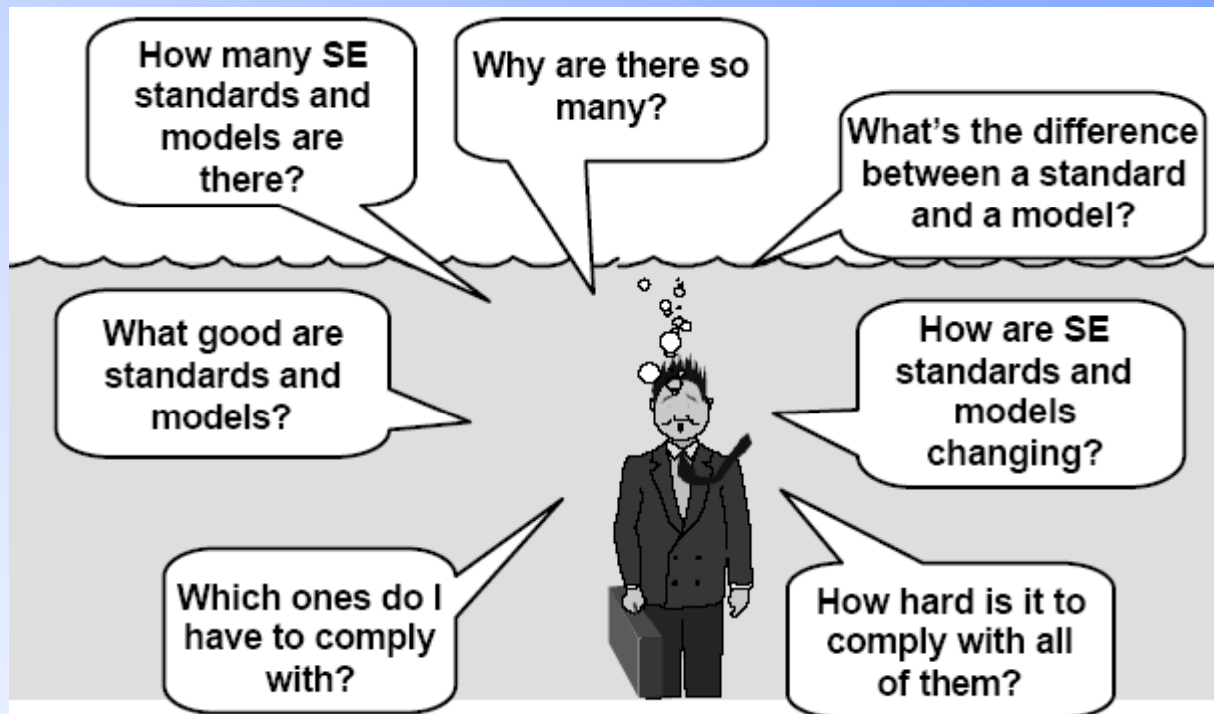

# Heritage of SE and SW Standards

## Systems

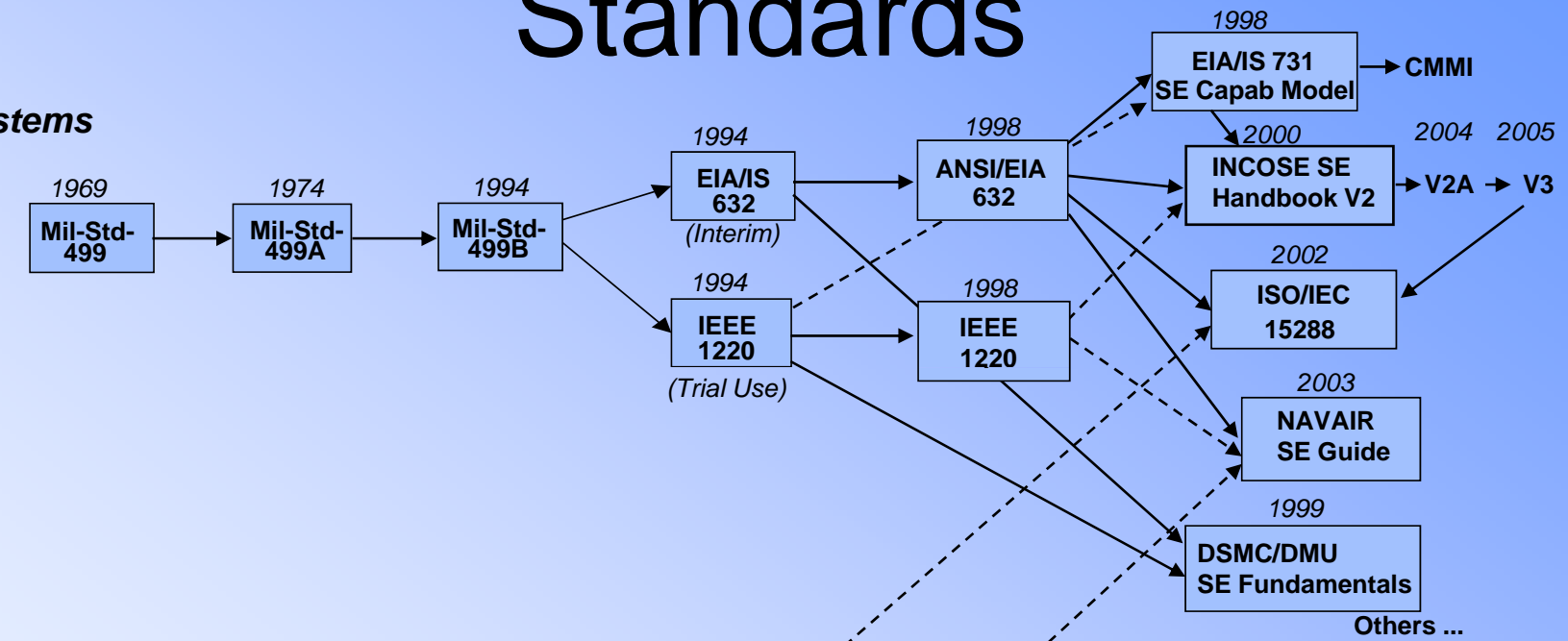

## Software

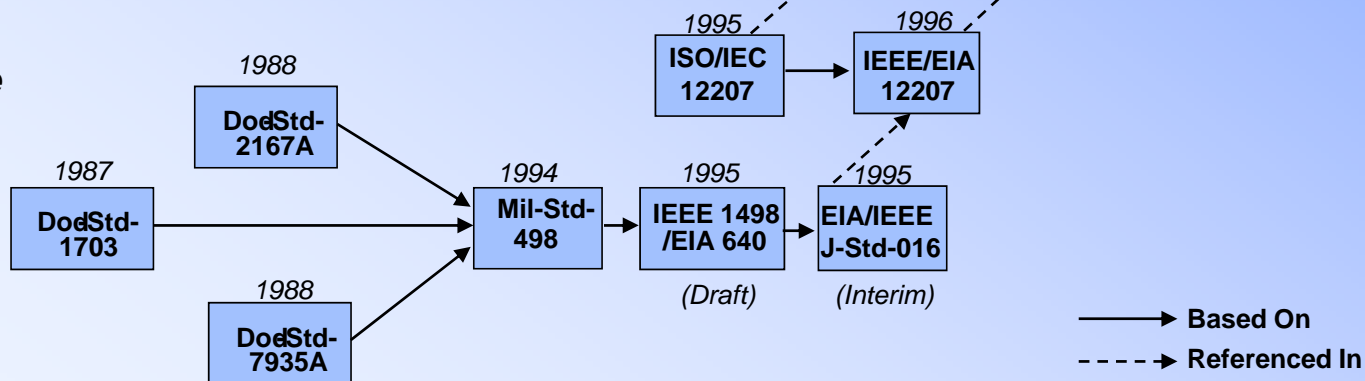

———> Based On  
 - - - -> Referenced In

# ISO/IEC 15288 Processes

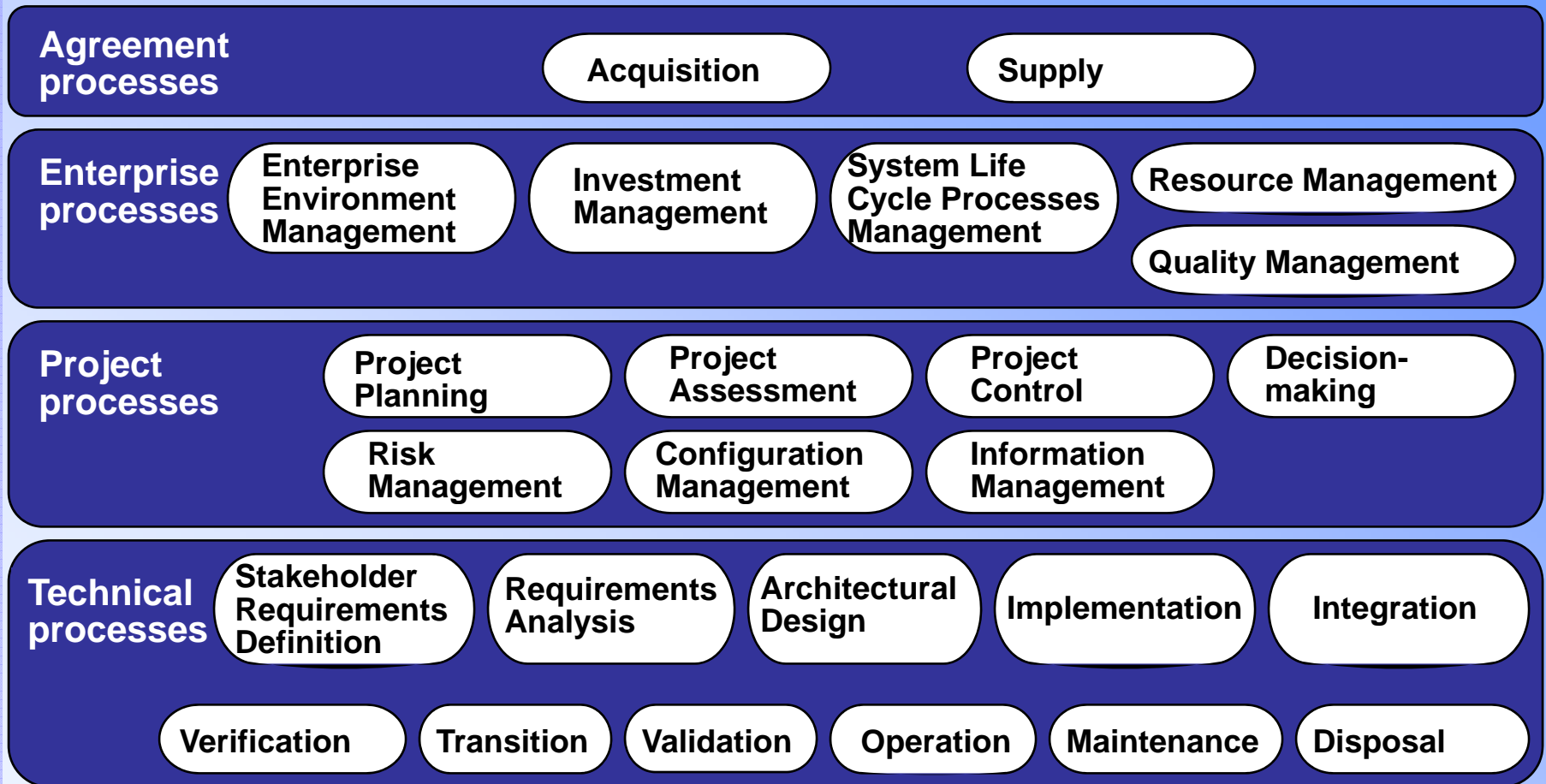

# ISO/IEC 15288 Lifecycle, Processes and Activities

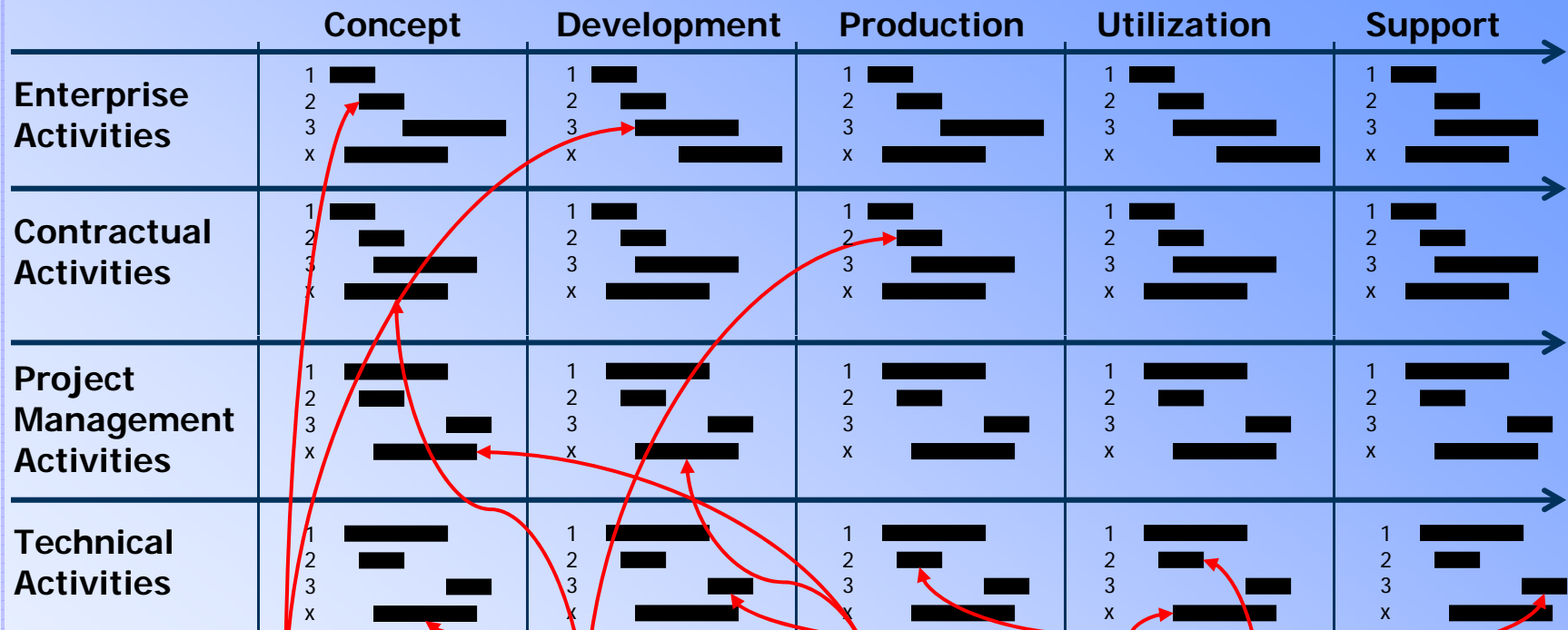

*Processes*

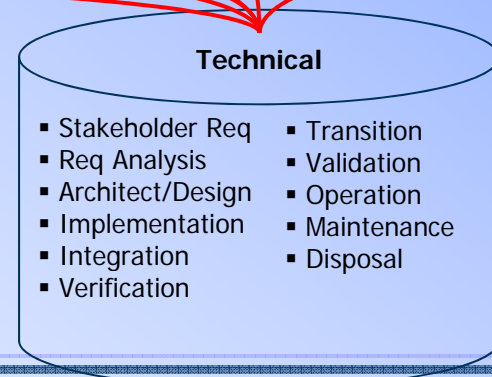
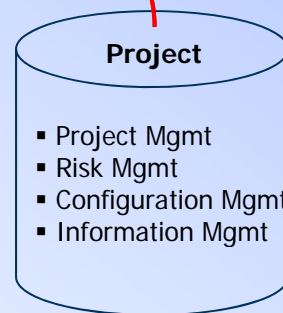
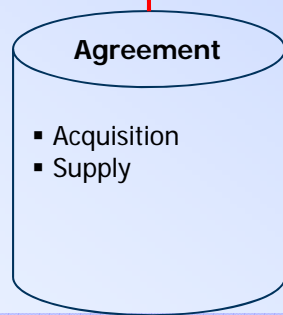
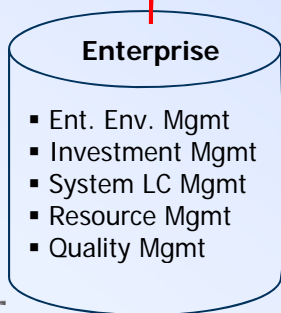

Source: <http://15288.com/>

# ISO/IEC 15288 View of the World

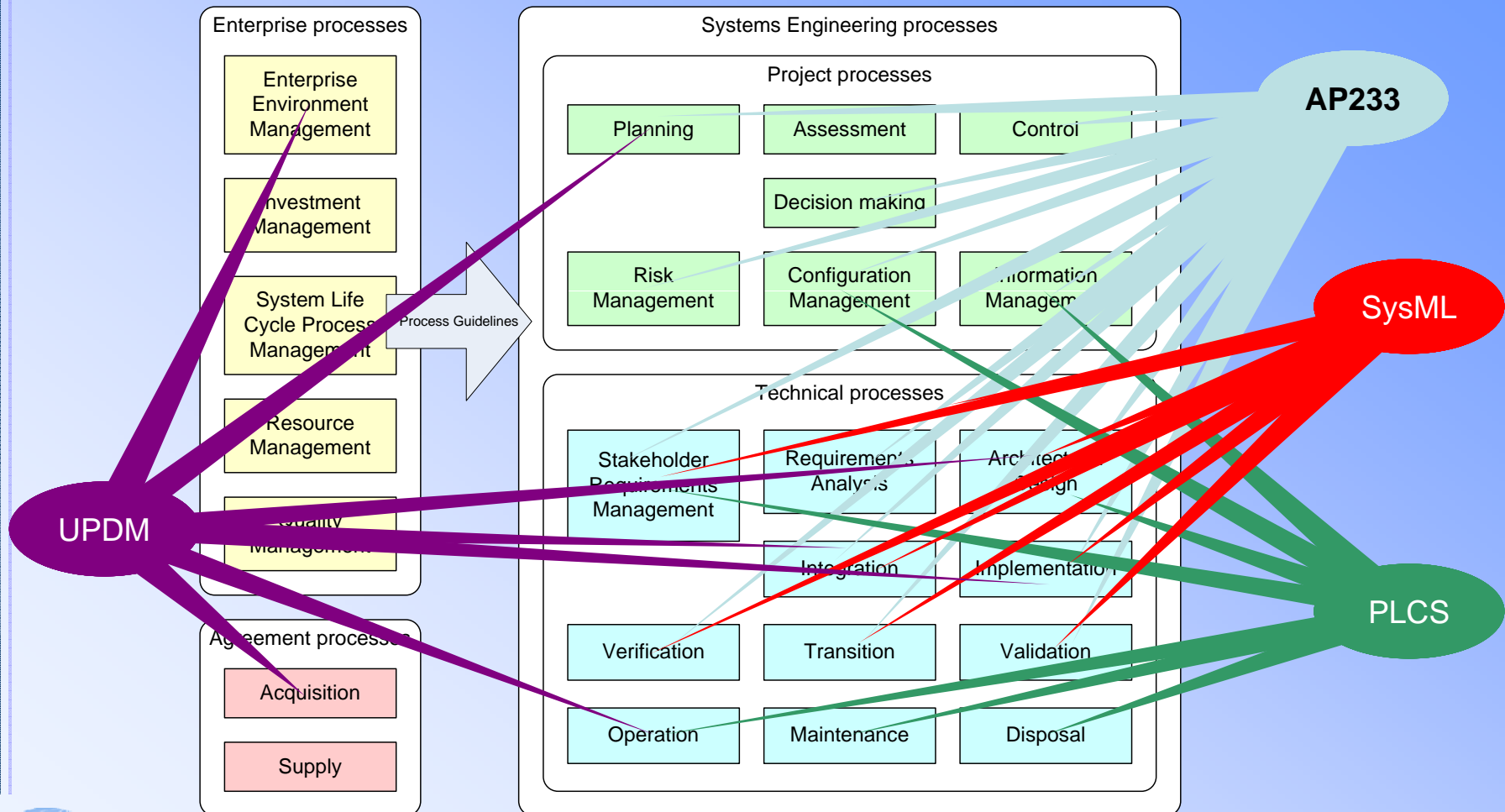

# Why Standards, Why Models?



Engineers Can't Speak or Write in a Common Language



When we go to the board, we create models  
It is our nature since the day of the caveman.

Systems Engineering Domain is the largest remaining discipline to embrace Model Driven Design, Model Driven Architecture and the associated processes and toolsets – our turn is here and **INTEROPERABILITY** is still in Our future.

# Q&A