



Implementation of a Methodology Supporting a Comprehensive System of Systems Maturity Analysis for use by the Littoral Combat Ship Mission Modules Program

INCOSE Chesapeake Chapter Dinner Meeting
19 August 2009

Richard Volkert
US Navy, SSC - Pacific

Eric Forbes
Northrop Grumman

Ken Michaud
US Navy, PEO LMW / PMS 420

Peter Gentile
Northrop Grumman

Tom Sondi
Northrop Grumman

Overview

- The System of Systems Challenge
- SRL Methodology Review
- Application to Development Status Monitoring
- Application to Technology Insertion
- Examining Connections to Cost and Performance

*Material presented at 2009 Naval Postgraduate School
Acquisition Research Symposium*

A Paradigm Shift in Design...

System-of-Systems Engineering and **Systems Engineering** are related but different fields of study. Traditional systems engineering seeks to optimize an **individual system** (i.e., the product), while SoSE seeks to optimize a **network of various interacting legacy and new systems** brought together to satisfy multiple objectives of the program. SoSE should enable the decision-makers to understand the implications of various choices on technical performance, costs, extensibility and flexibility over time; thus, *effective SoSE methodology should prepare decision-makers to design informed architectural solutions for SoSE problems.*

-Wikipedia

Unique SoS Acquisition Management Needs

- SoS acquisition management represents a significant increase in complexity over traditional system acquisition
- Development requires that significant numbers of new and existing technologies be integrated to one another in a variety of ways
- Poses challenges to traditional development monitoring tools and cost models due to the need to capture integration complexity and the level of effort required to connect individual components
- A high degree of inter-linkage between components can also cause unintended consequences to overall system performance as components are modified and replaced throughout the system life cycle

The result of this acquisition management challenge has been significant schedule and cost overruns in SoS programs

LCS Mission Packages... truly a SoS undertaking



Surface Warfare
(SUW)

Mine Countermeasures
(MCM)

Anti-Submarine Warfare
(ASW)

LCS Mission Package Defined

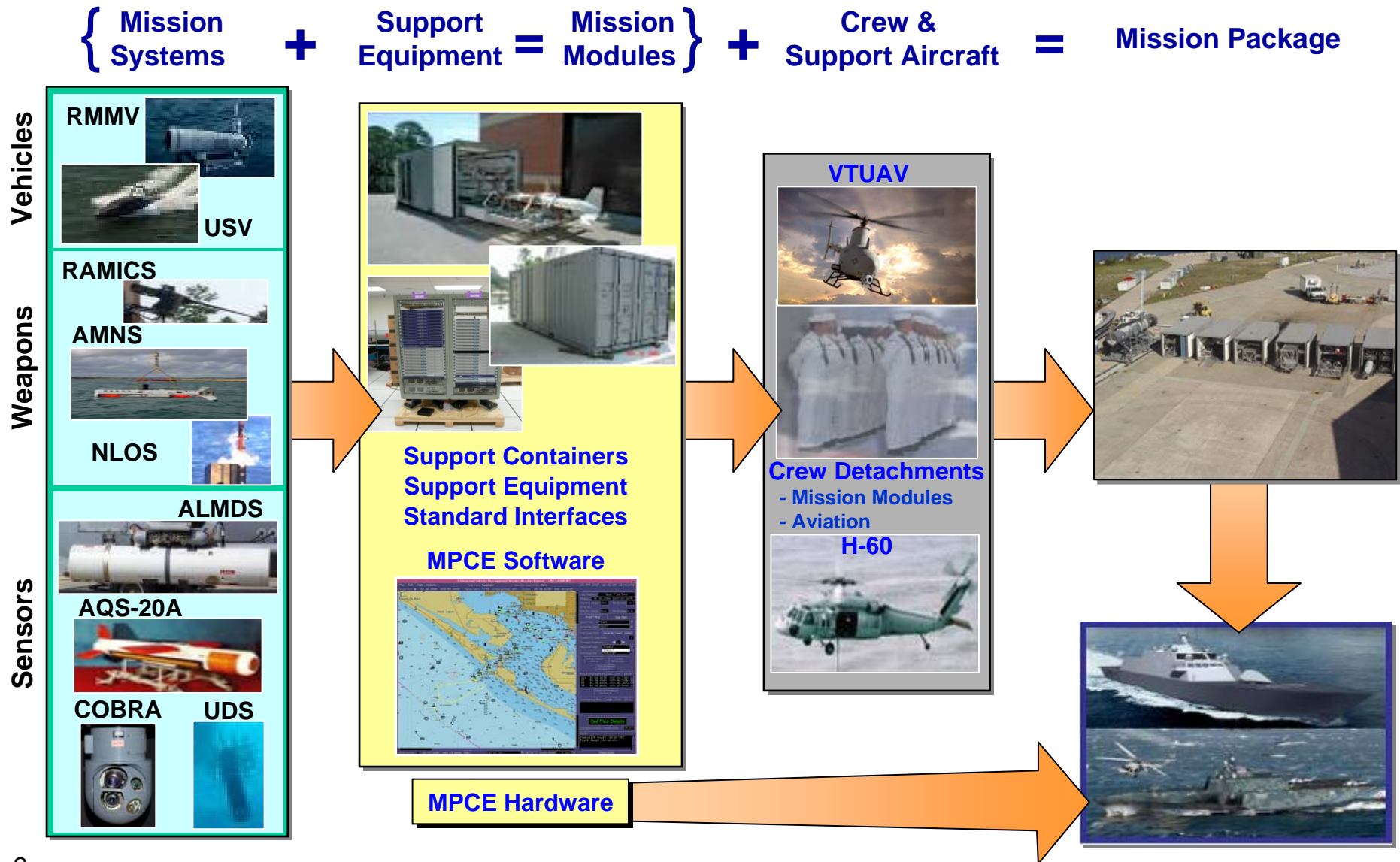

Defining Program Office Needs

- PEO LMW / PMS 420 is responsible for the development and integration of a series of Mission Modules to be used on the Littoral Combat Ship
- Modules leverage considerable amounts of technology from existing programs of record while also conducting new development
- Key aspects of the project include not only monitoring the status of technology development, but also the maturity of the numerous integrations between those technologies
- This has resulted in a very complex and diverse system of systems engineering activity with a need to obtain quick and accurate snapshots of program status, risks, and issues





SRL Methodology Review

TRL Shortcomings

- Application of TRL to systems of technologies is not sufficient to give a holistic picture of complex system of systems readiness
 - TRL is only a measure of an individual technology
- Assessments of several technologies rapidly becomes very complex without a systematic method of comparison
- Multiple TRLs do not provide insight into integrations between technologies nor the maturity of the resulting system
 - Yet most complex systems fail at the integration points

Individual Technology



Can TRL be applied?

Yes

System of Technologies

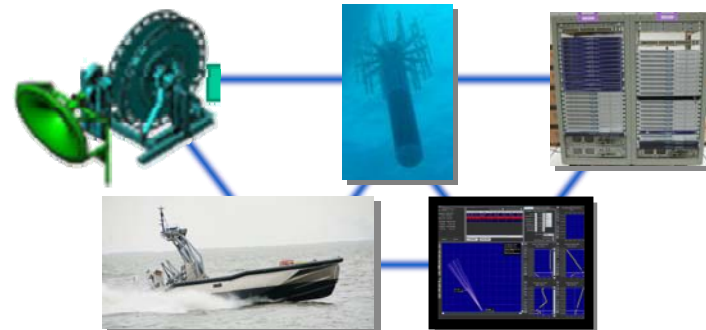

Can TRL be applied?

NO

Methodology Development Overview

GOAL: Institute a robust, repeatable, and agile method to monitor / report system development and integration status

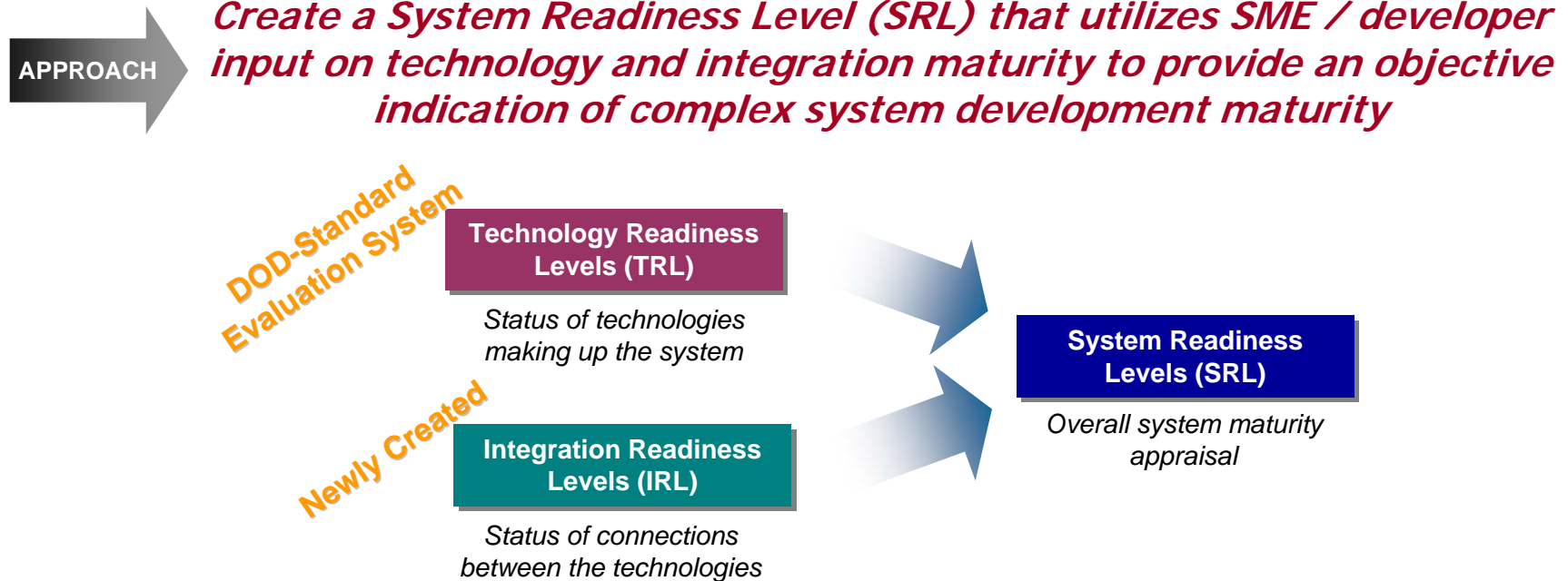

- Provides a **system-level** view of development maturity with opportunities to drill down to element-level contributions
- Allows managers to evaluate system development in real-time and take **proactive** measures
- Highly **adaptive** to use on a wide array of system engineering development efforts
- Can be applied as a **predictive** tool for technology insertion trade studies and analysis

SRL Methodology and Analysis Flow

Step 1: Identify hardware and software components

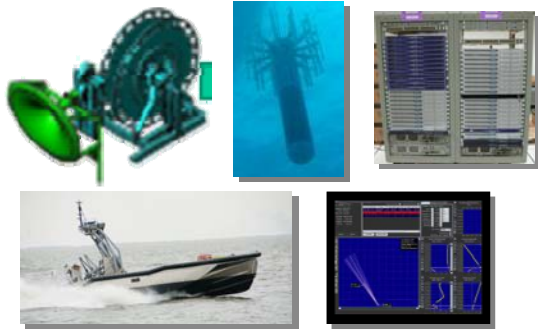

Include all technologies that make-up the overall system

Step 2: Define network diagram for systems

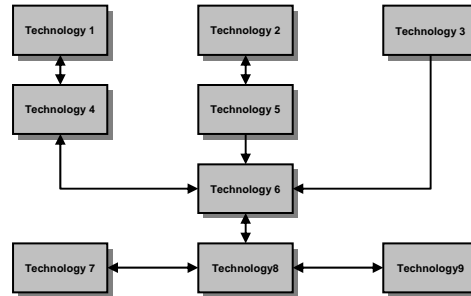

Emphasis is on the proper depiction of hardware and software integration between the components

Step 3: Define system operational strings (If applicable)

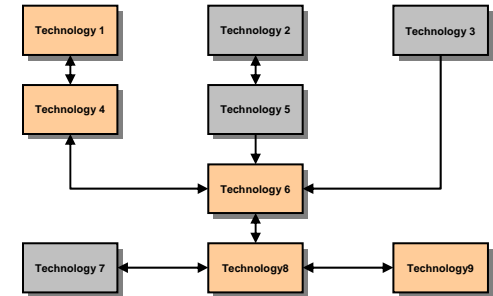

String analysis allows for the option of weighting the most important components and evaluation of alternate operational states

Initial Architecture Definition and Setup

Step 4: Apply detailed TRL and IRL evaluation criteria to components and integrations

Integration Maturity Level 1	
100	Components to be integrated are selected
100	Component interface points are identified
100	Documented phase/build plan for component availability
100	Data buses identified

Technology Readiness Level 1	
100	Physical laws and assumptions used in new technologies defined
50	Have some concept in mind that may be realizable in software
25	Know what software needs to do in general terms
30	Paper studies confirm basic principles and system concepts
N/A	Mathematical formulations of concepts that might be realizable in software
100	Have an idea that captures the basic principles of a possible algorithm
0	Basic scientific principles observed
100	Research hypothesis formulated
75	Identify who will perform research and where it will be done
60	Readiness Level Percent Complete (non-weighted)

Checklist style evaluation allows for the ability to "take-credit" for steps that have taken place beyond the current readiness level

Step 5: Calculate individual and composite SRLs

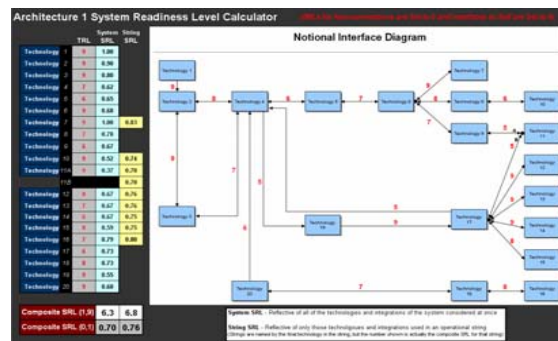

Input TRL and IRL evaluations into algorithm to compute an assessment of overall system status via SRLs

Step 6: Document status via roll-up charts

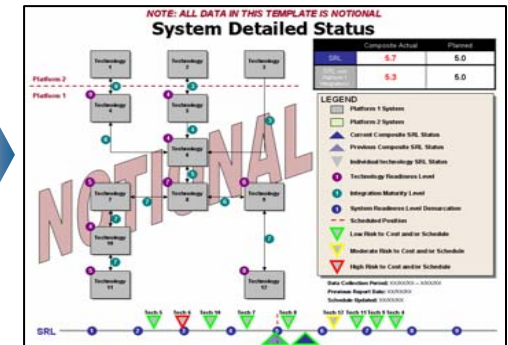

Populate reporting chart templates with evaluation and calculation outcomes to highlight both current status and performance over time

SRL Calculation

- The SRL is not user defined, but is instead based on the outcomes of the documented TRL and IRL evaluations
- Through mathematically combining these two separate readiness levels, a better picture of overall complex system readiness is obtained by examining all technologies in concert with all of their required integrations

$$\mathbf{SRL = IRL \times TRL}$$

$$\begin{pmatrix} \mathbf{SRL}_1 & \mathbf{SRL}_2 & \mathbf{SRL}_3 \end{pmatrix} = \begin{pmatrix} \mathbf{IRL}_{11} & \mathbf{IRL}_{12} & \mathbf{IRL}_{13} \\ \mathbf{IRL}_{12} & \mathbf{IRL}_{22} & \mathbf{IRL}_{23} \\ \mathbf{IRL}_{13} & \mathbf{IRL}_{23} & \mathbf{IRL}_{33} \end{pmatrix} \times \begin{pmatrix} \mathbf{TRL}_1 \\ \mathbf{TRL}_2 \\ \mathbf{TRL}_3 \end{pmatrix}$$

$$\begin{aligned} \mathbf{Composite\ SRL} &= \mathbf{1/n} \left(\mathbf{SRL}_1/\mathbf{n} + \mathbf{SRL}_2/\mathbf{n} + \mathbf{SRL}_3/\mathbf{n} \right) \\ &= \mathbf{1/n^2} \left(\mathbf{SRL}_1 + \mathbf{SRL}_2 + \mathbf{SRL}_3 \right) \end{aligned}$$

- These values serve as a decision-making tool as they provide a prioritization guide of the system's technologies and integrations and point out deficiencies in the maturation process

SRL Calculation Example

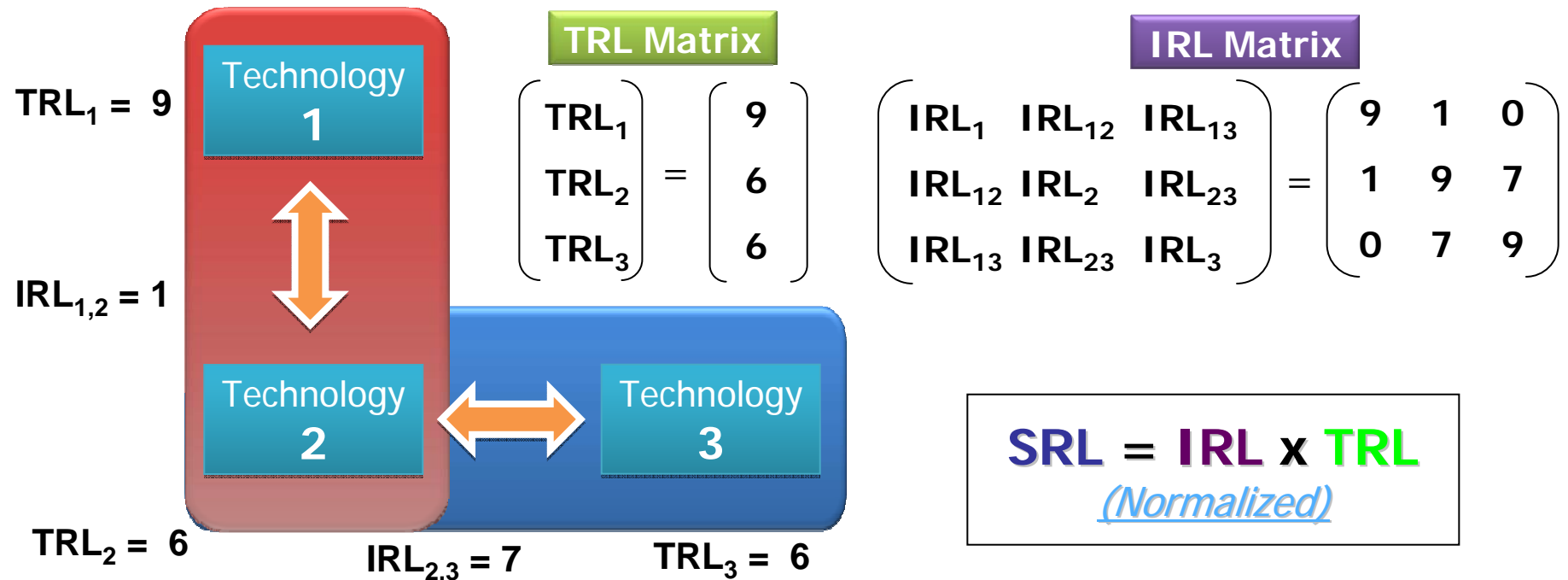

$$\text{Component SRL} = \begin{pmatrix} \text{SRL}_1 & \text{SRL}_2 & \text{SRL}_3 \end{pmatrix} = \begin{pmatrix} 0.54 & 0.43 & 0.59 \end{pmatrix}$$

Component SRL_x represents Technology "X" and its IRLs considered

$$\text{Composite SRL} = 1/3 (0.54 + 0.43 + 0.59) = 0.52$$

The Composite SRL provides an overall assessment of the system readiness

SRL Reporting Method

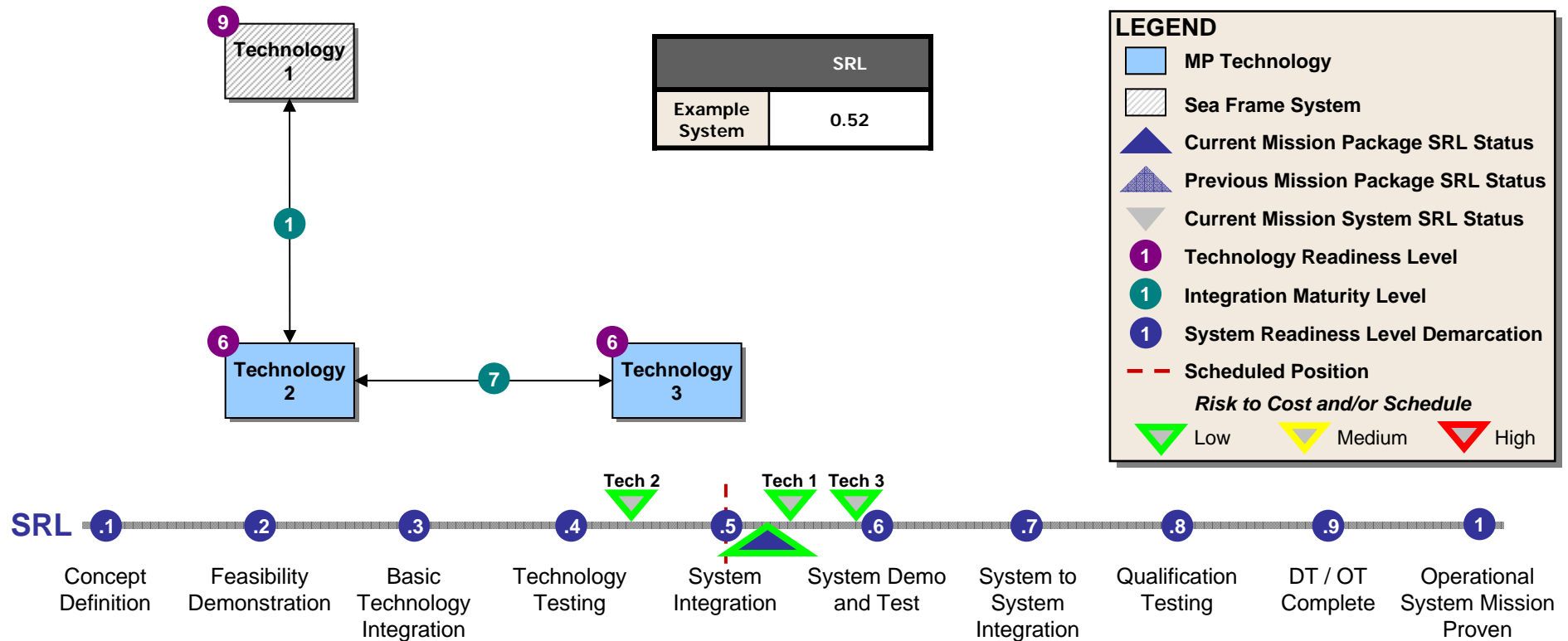

- For complex systems, the amount of information obtained from the SRL evaluation can be overwhelming
- To maximize applicability SRL outputs are tied to key, program- specific development milestones
- Progress against these milestones provide key insight to the user regarding current program status, risk and progress



Application to Development Status Monitoring

Applications in Management Decision Making

- **Current development status monitoring**
 - Enables monitoring of system technology maturation with all integrations considered
 - Enables a prioritization of technology development maturity for each component of the system
- **Decision making**
 - Allows components identified as “lagging” to be analyzed further for root cause
 - Resources can be more properly distributed to those technologies in need
 - Impacts can be examined by quickly analyzing multiple “what-if” scenarios
 - Allows projected maturity changes to be examined along with cost and schedule

In complex SoS efforts it is not always immediately clear where resources should be applied for maximum gains in maturity and reductions in risk

Analyzing the Unexpected

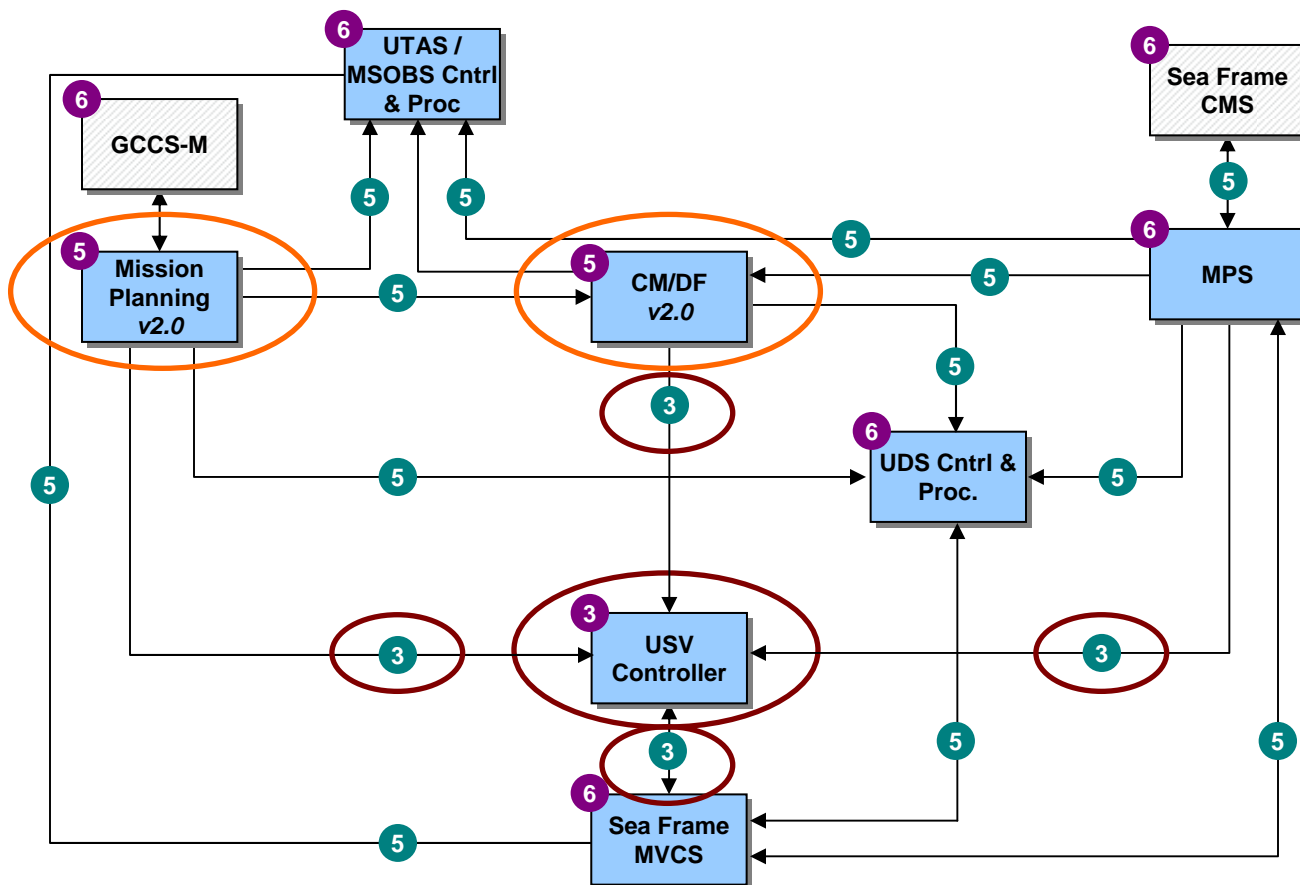

	MP SRL	MP SRL w/o Sea Frame
MP SW	0.39	0.35

LEGEND

- MP Technology
- Sea Frame System
- Current Mission Package SRL Status
- Previous Mission Package SRL Status
- Current Mission System SRL Status
- 1 Technology Readiness Level
- 1 Integration Maturity Level
- 1 System Readiness Level Demarcation
- Scheduled Position

Risk to Cost and/or Schedule

- Low
- Medium
- High

A component has fallen behind its planned development progression, creating a programmatic risk

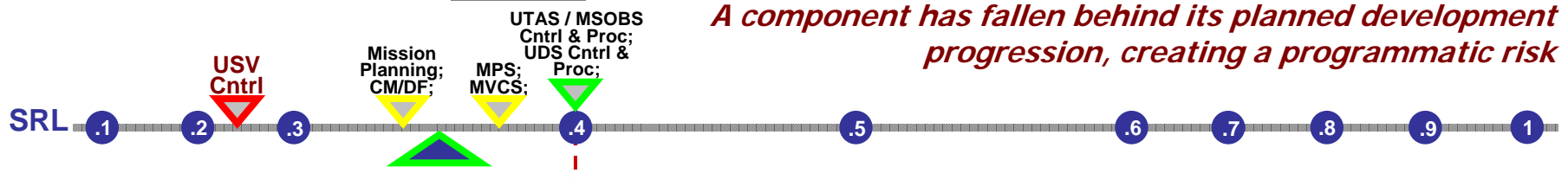

Effectively Channeling Resources

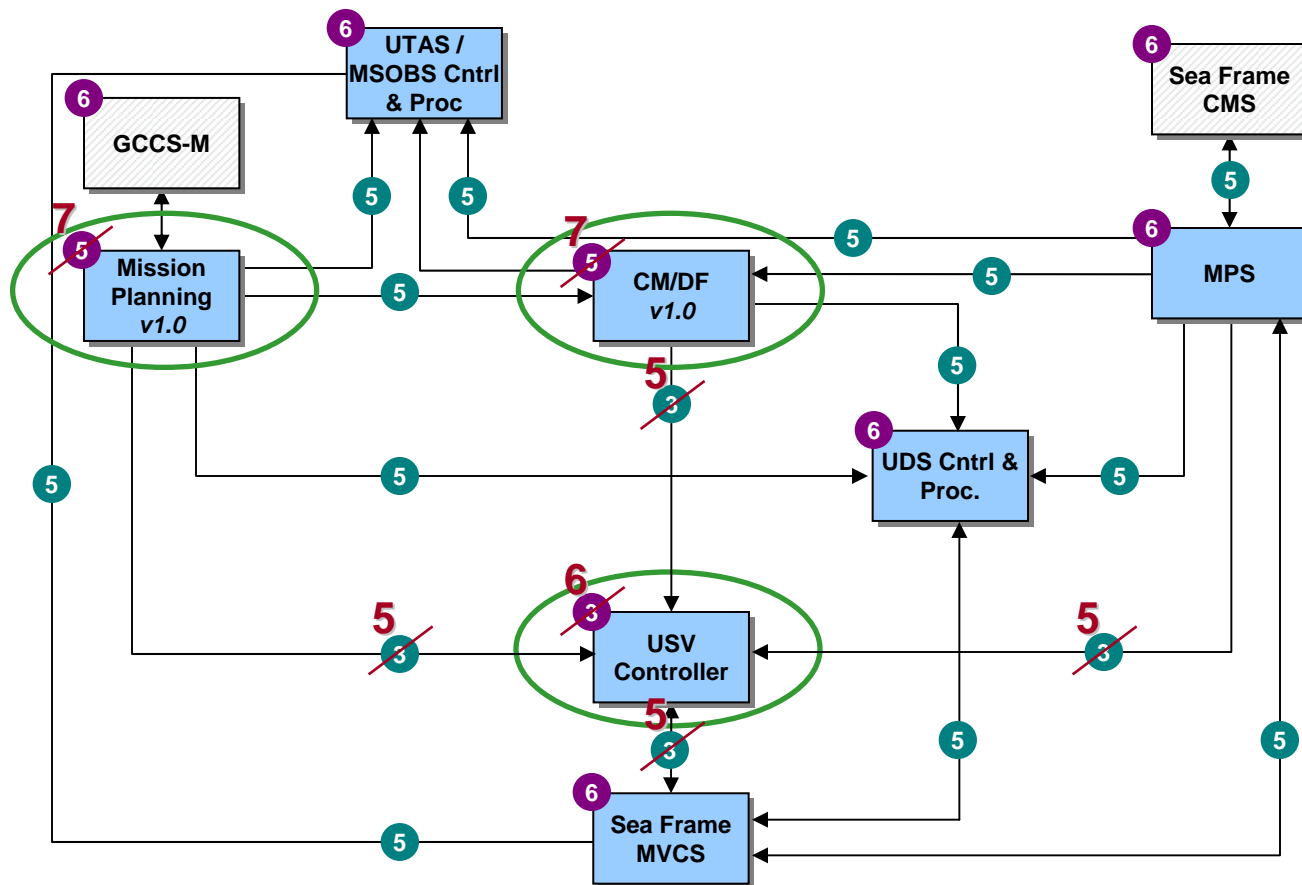

	MP SRL	MP SRL w/o Sea Frame
MP SW	0.46 0.39	0.45 0.35

LEGEND

- MP Technology (Blue box)
- Sea Frame System (Hatched box)
- Current Mission Package SRL Status (Blue triangle)
- Previous Mission Package SRL Status (Hatched triangle)
- Current Mission System SRL Status (Grey triangle)
- Technology Readiness Level (Purple circle)
- Integration Maturity Level (Green circle)
- System Readiness Level Demarcation (Blue circle)
- Scheduled Position (Red dashed line)
- Risk to Cost and/or Schedule:
 - Low (Green inverted triangle)
 - Medium (Yellow inverted triangle)
 - High (Red inverted triangle)

6 months later...

A re-distribution of resources has allowed the lagging component to catch-up

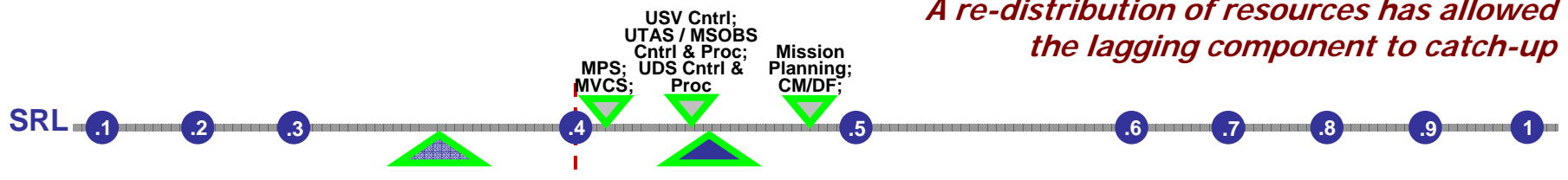



Application to Technology Insertion

Technology Insertion in SoS's

As with the monitoring of current status in SoS's, the process of technology identification, analysis and insertion is also made considerably more complex

Key Questions to Consider Include:

- Which of the existing components of the system should be either replaced or enhanced?
- How will the new technology be integrated into the system?
- What are the types of integration involved?
 - *Logical / Data flow*
 - *Physical*
 - *Functional*
 - *Human-to-Machine*
- What is the projected impact on performance? (How do we optimize?)
- Are there any legacy design constraints that will impact selection?

Case Study – Considerations for Legacy Systems

- **Background:**
 - Massachusetts Bay Transit Authority needed new light rail cars to enhance handicapped access
- **Legacy System Description:**
 - Oldest light rail system in North America with some infrastructure dating back over 100 years
 - New cars would need to operate in conjunction with existing rolling stock
- **Design Solution:**
 - Leveraged completely mature and well understood component technologies in a new design
- **Outcome:**
 - Fielded prototype experienced four years of braking performance issues and derailments causing repeated withdrawals from service



SOURCE: Fraser, G.R., Leary, R.J., Pellegrini, M.M.C., *Integrating New Light Rail Vehicle Technology in Mature Infrastructure*, Transportation Research Circular EC-058, 9th National Light Rail Transit Conference.

Case Study – What Went Wrong???

- Well proven technologies integrated with one another in new ways and into an existing infrastructure created unintended issues including:
 - *Difficulties in matching the new car's acceleration and braking performance to existing car's capabilities due to inherent characteristics of technologies employed*
 - *Introduction of an "advanced" wheel design that was unable to accommodate an infrastructure that has deviated from original design specifications over years of use*
- In all cases the design met **requirements**, but failed to adequately accommodate the **constraints** imposed by the overall system and environment

Performance of a technology in a stand-alone environment does not mean that the technology can be inserted at the system level without significant planning, monitoring, and assessment

Trading Off Technology Insertion Options

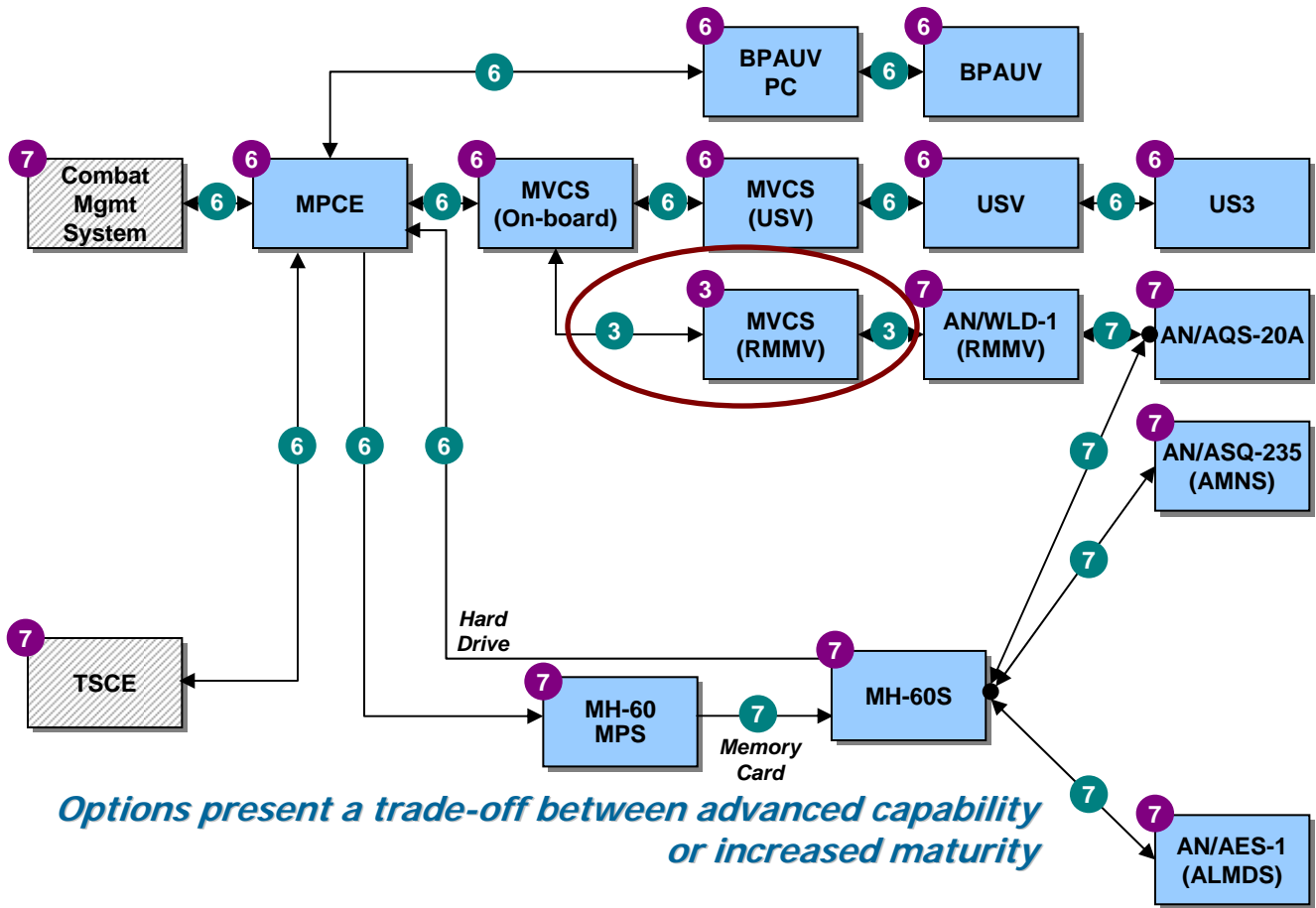

	MP SRL	MP SRL w/o Sea Frame
MP 1	0.60	0.57

LEGEND

- MP Technology
- Sea Frame System
- ▲ Current Mission Package SRL Status
- ▲ Previous Mission Package SRL Status
- ▼ Current Mission System SRL Status
- 1 Technology Readiness Level
- 1 Integration Maturity Level
- 1 System Readiness Level Demarcation
- Scheduled Position

Risk to Cost and/or Schedule

- Low
- Medium
- High

Options present a trade-off between advanced capability or increased maturity

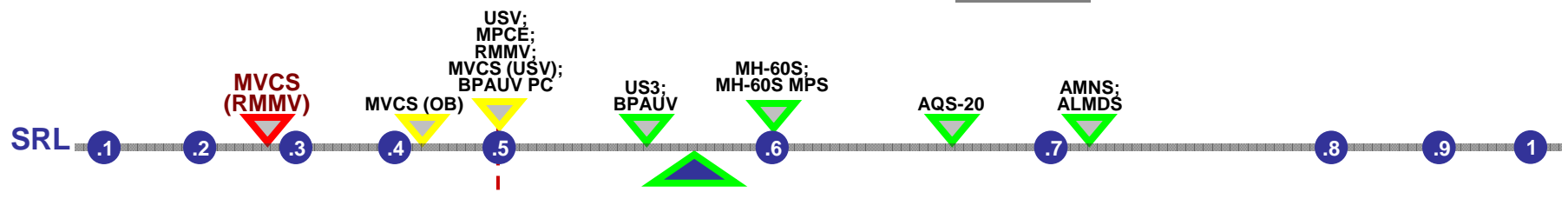

Taking Action to Mitigate Risk

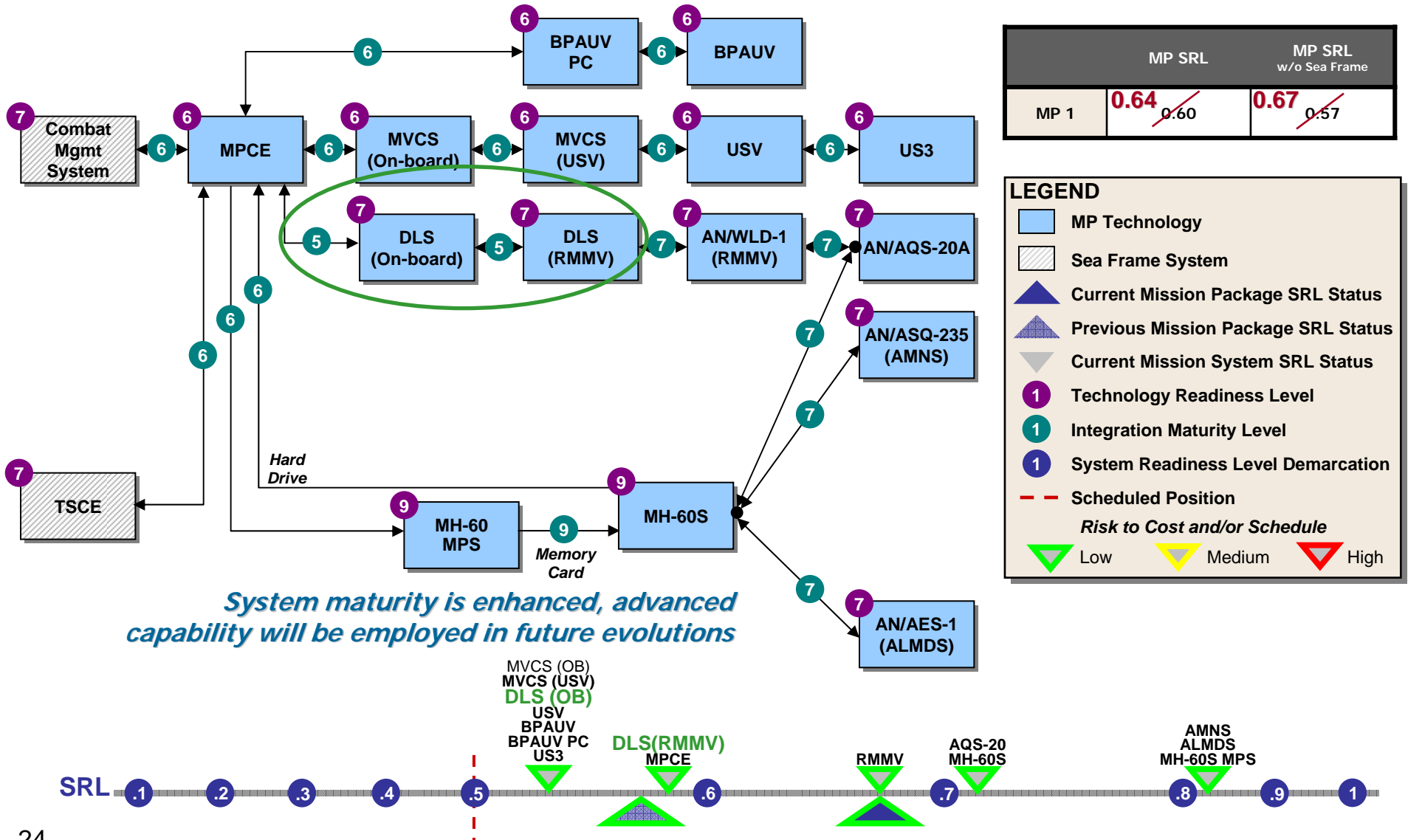



Examining Connections to Cost and Performance

Cost Profiles

- PEO LMW / PMS 420 is working with NAVSEA 05C (NAVSEA's cost analysis division) to develop a life cycle cost model specifically tailored to SoS analysis
- Factors contributing to costs in SoS
 - *Integration type (physical, functional, logical)*
 - *Use of standards (Were components designed to integrate?)*
 - *Maturity of technologies being integrated*
- A correlation between the SRL and cost numbers brings about the ability to track actual development maturity vs. costs
- Linkage to technology trade-off and planning environments allows cost to be analyzed in consideration with maturity and performance
- Concept being explored by Stevens Institute would allow for overall program cost estimate funding allocations to be discredited over the development cycle

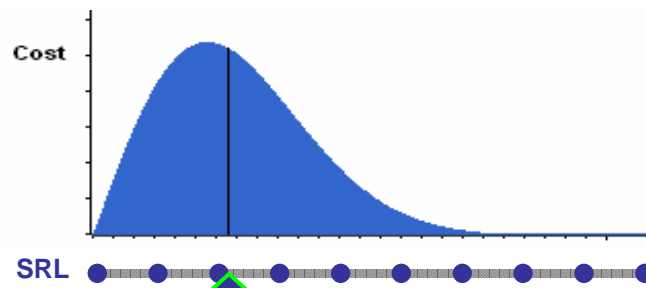

Example Reporting Format

Total R&D Cost

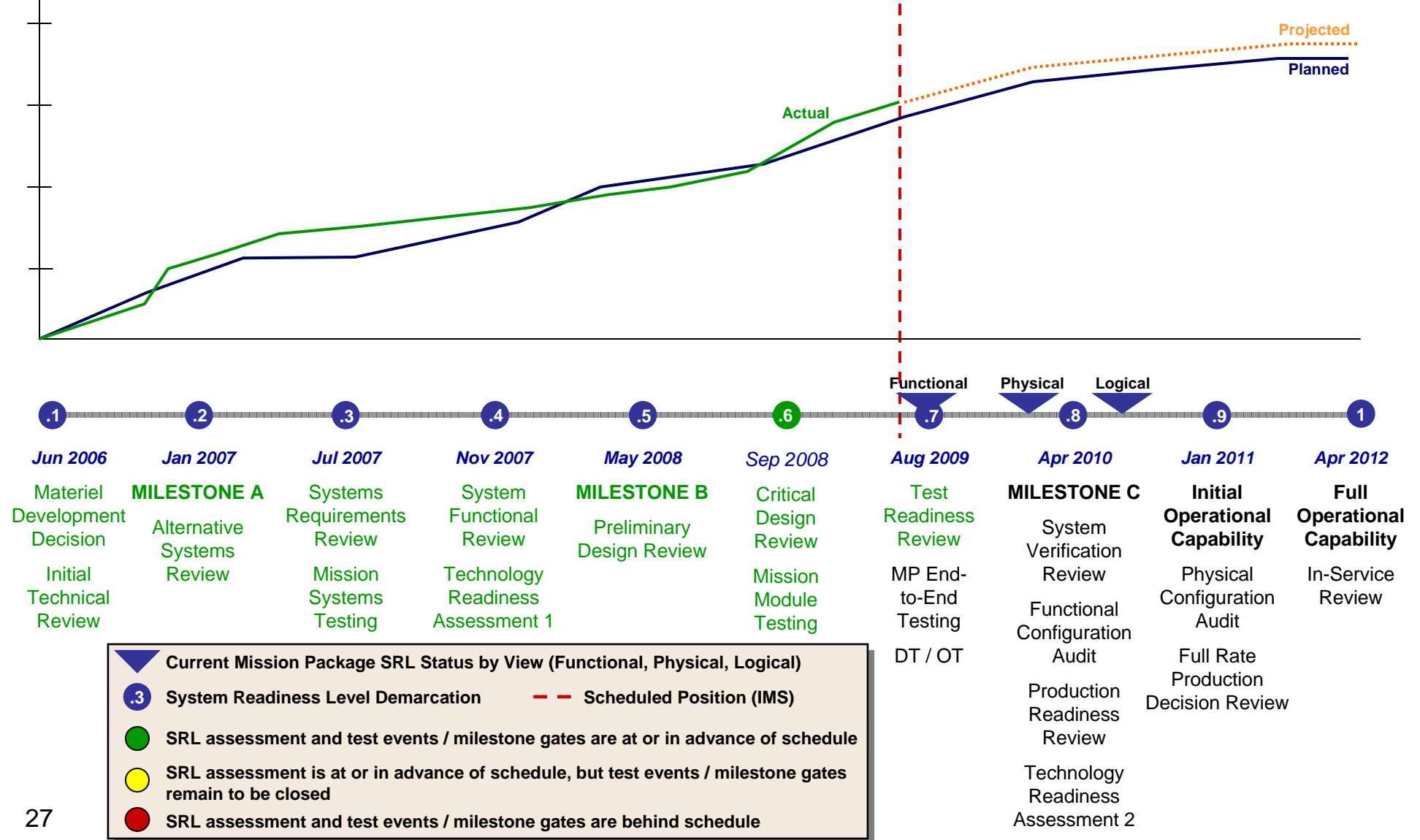

Connecting Maturity to Requirements and Performance

- SRL provides considerable insight into development maturity, but how can we capture whether that system is meeting performance?
 - *Parallel scale will link demonstrated system performance via requirements, KPPs, and TPMs, which can then be traded against cost and maturity*

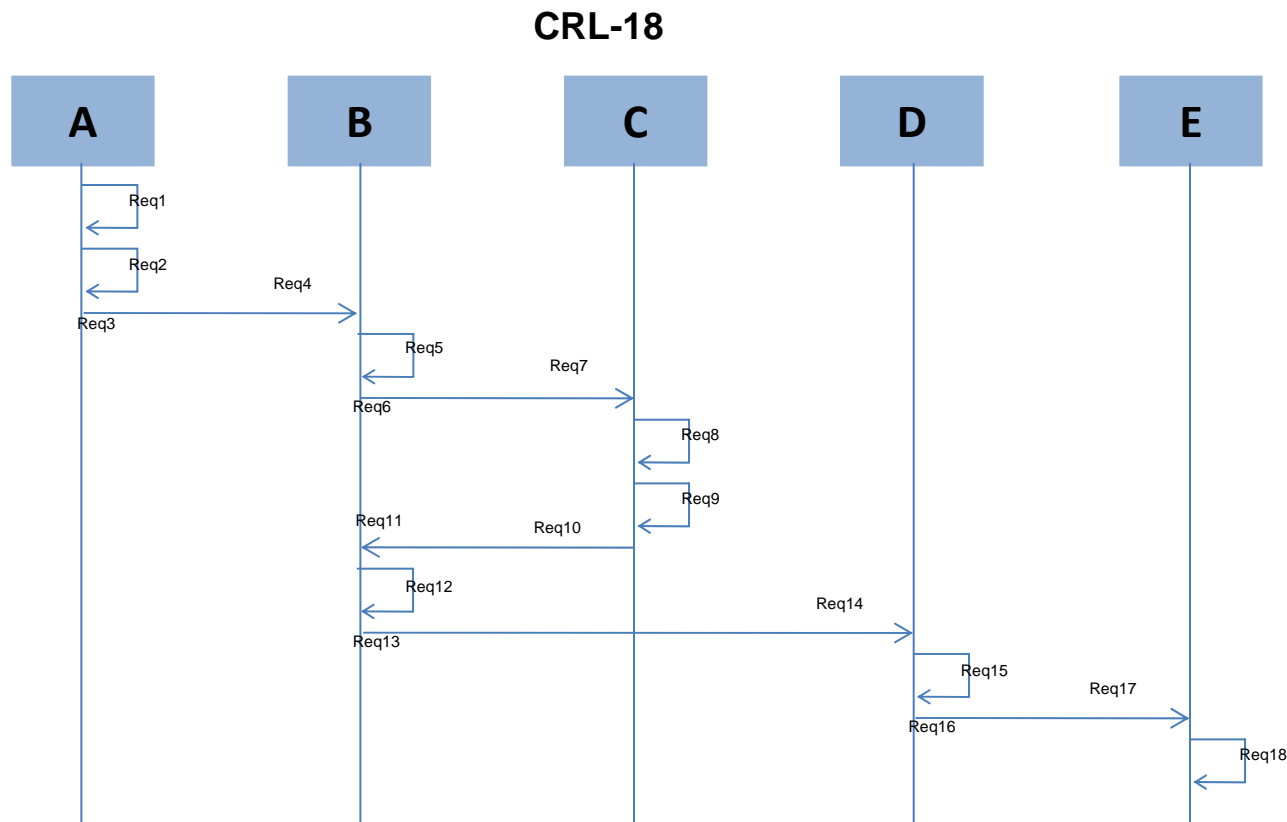

Conclusions

- SoS development represents a new level of challenge in acquisition management
- SRL provides one possible assessment, analysis and management technique
- Methodology leads to holistic monitoring of many factors impacting system development
 - Capturing integration is key
- Future work includes extending the concepts for understanding cost and performance impacts in an incremental acquisition



QUESTIONS?



Back-up

Detailed SRL Calculation Example

Matrix Setup

- The computation of the SRL is a function of two matrices:
 - The TRL Matrix provides a blueprint of the state of the system with respect to the readiness of its technologies. That is, TRL is defined as a vector with n entries for which the k th entry defines the TRL of the k th technology.
 - The IRL Matrix illustrates how the different technologies are integrated with each other from a system perspective. IRL is defined as an $n \times n$ matrix for which the element IRL_{ij} represents the maturity of integration between the i th and j th technologies.
- Populate these matrices with the appropriate values from the previously documented TRL and IRL component evaluations and then normalize to a (0,1) scale by dividing through by 9
- For an integration of a technology to itself (e.g. IRL_{nn}) a value of "9" should be placed in the matrix
- For an instance of no integration between technologies a value of "0" should be placed in the matrix

$$[TRL]_{n \times 1} = \begin{bmatrix} TRL_1 \\ TRL_2 \\ \dots \\ TRL_n \end{bmatrix} \quad [IML]_{n \times n} = \begin{bmatrix} IML_{11} & IML_{12} & \dots & IML_{1n} \\ IML_{21} & IML_{22} & \dots & IML_{2n} \\ \dots & \dots & \dots & \dots \\ IML_{n1} & IML_{n2} & \dots & IML_{nn} \end{bmatrix}$$

Detailed SRL Calculation Example

Calculation

- Obtain an SRL matrix by finding the product of the TRL and IRL matrices

$$[SRL]_{n \times 1} = [IML]_{n \times n} \times [TRL]_{n \times 1}$$

- The SRL matrix consists of one element for each of the constituent technologies and, from an integration perspective, quantifies the readiness level of a specific technology with respect to every other technology in the system while also accounting for the development state of each technology through TRL. Mathematically, for a system with n technologies, [SRL] is:

$$[SRL] = \begin{bmatrix} SRL_1 \\ SRL_2 \\ \dots \\ SRL_n \end{bmatrix} = \begin{bmatrix} IML_{11}TRL_1 + IML_{12}TRL_2 + \dots + IML_{1n}TRL_n \\ IML_{21}TRL_1 + IML_{22}TRL_2 + \dots + IML_{2n}TRL_n \\ \dots \\ IML_{n1}TRL_1 + IML_{n2}TRL_2 + \dots + IML_{nn}TRL_n \end{bmatrix}$$

Detailed SRL Calculation Example

Analysis

- Each of the SRL values obtained from the previous calculation would fall within the interval (0, # of Integrations for that Row). For consistency, these values of SRL should be divided by the number of integrations for that row of the matrix to obtain the normalized value between (0,1). (e.g. if there are four non-zero numbers in the IRL matrix for that row, divide by four)
- This number should then be multiplied by 9 to return to the familiar (1,9) scale
- For Example:

$$\begin{pmatrix} \text{IRL}_1 & \text{IRL}_{12} & \text{IRL}_{13} \\ \text{IRL}_{12} & \text{IRL}_2 & \text{IRL}_{23} \\ \text{IRL}_{13} & \text{IRL}_{23} & \text{IRL}_3 \end{pmatrix} = \begin{pmatrix} 0 & 1 & 0 \\ 1 & 0 & 7 \\ 0 & 7 & 0 \end{pmatrix}$$

← **1 Integration** (Divide SRL for that Row by 1 and multiply by 9)
 ← **2 Integrations** (Divide SRL for that Row by 2 and multiply by 9)
 ← **1 Integration** (Divide SRL for that Row by 1 and multiply by 9)

Detailed SRL Calculation Example

Analysis



$$SRL = \left[SRL_1 \quad SRL_2 \quad SRL_3 \right]$$

- These individual values serve as a decision-making tool as they provide a prioritization guide of the system's technologies and integrations and point out deficiencies in the maturation process
- The composite SRL for the complete system is the average of all normalized SRL values. (Note that weights can be incorporated here if desired.)

$$SRL_{Composite} = \frac{\left(\frac{SRL_1}{n} + \frac{SRL_2}{n} + \dots + \frac{SRL_n}{n} \right)}{n}$$

- A standard deviation can also be calculated to indicate the variation in the system maturity

SRL Calculation Example

Normalizing the TRLs and IRLs

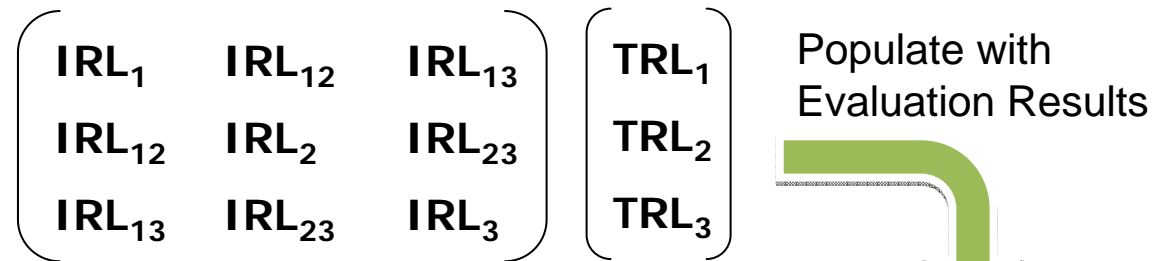

Non-Normalized [(1,9) scale]

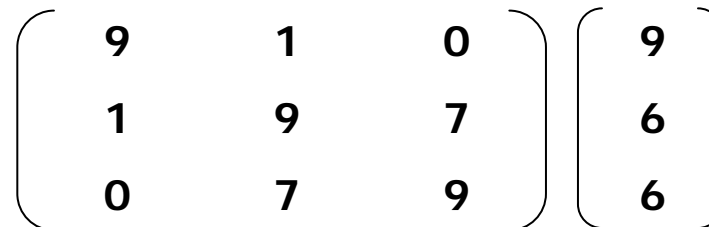

Normalized [(0,1) scale]

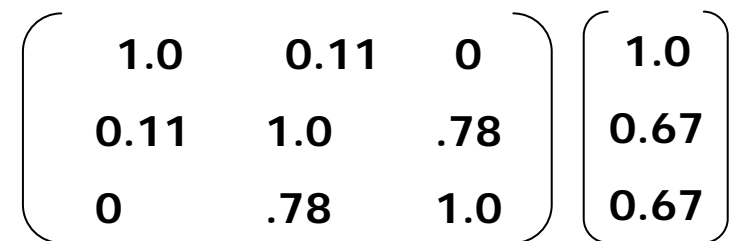

Remember... a technology integrated with itself receives an IRL value of 9 (e.g. IRL_{11}), while technologies for which there is no connection between them receive a value of 0 (e.g. IRL_{13}).

SRL for System Alpha

Calculating the SRL and Composite Matrix

$$\text{SRL} = \text{IRL} \times \text{TRL}$$

Component SRL

$$\begin{bmatrix} \text{SRL}_1 & \text{SRL}_2 & \text{SRL}_3 \end{bmatrix} = \begin{bmatrix} 1.07 & 1.30 & 1.19 \end{bmatrix} \quad \text{(0,n) scale}$$

Where "n" is equal to the number of integrations for that technology

$$\begin{bmatrix} \text{SRL}_1 & \text{SRL}_2 & \text{SRL}_3 \end{bmatrix} = \begin{bmatrix} 0.54 & 0.43 & 0.59 \end{bmatrix} \quad \text{(0,1) scale}$$

Component SRL_x represents Technology "X" and its IRLs considered

Composite SRL

$$\text{Composite SRL} = 1/3 (0.54 + 0.43 + 0.59)$$

$$= 0.52$$

The Composite SRL provides an overall assessment of the system readiness

Both individual and composite scores provide key insights into the actual maturity of the system as well as where risk may lie and attention directed for greatest benefit

"String" Analysis Incorporated

Complex systems often offer numerous options for conducting operations

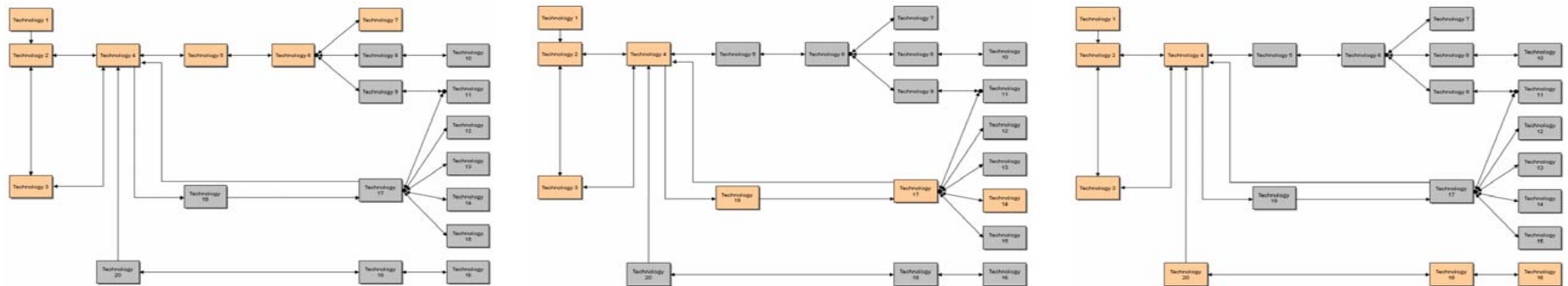

- Operational strings were created that identified the components required to utilize a single function of the system
- Assessment of the SRL for each of these options allows for a better understanding of the maturity of each operating configuration
- Understanding the true status of the system on an operational string level allows for the opportunity to field initial capability earlier and then add to it as other strings mature

SRL Calculators Developed

- Calculators are developed and defined for the system being evaluated
- Allows for real-time updates to TRL and IRL inputs and the resulting SRL evaluation providing decision-makers with instant feedback on “what if” scenarios
- Intuitive interface removes the need for the user to manipulate and deal with the mathematics of the SRL calculation

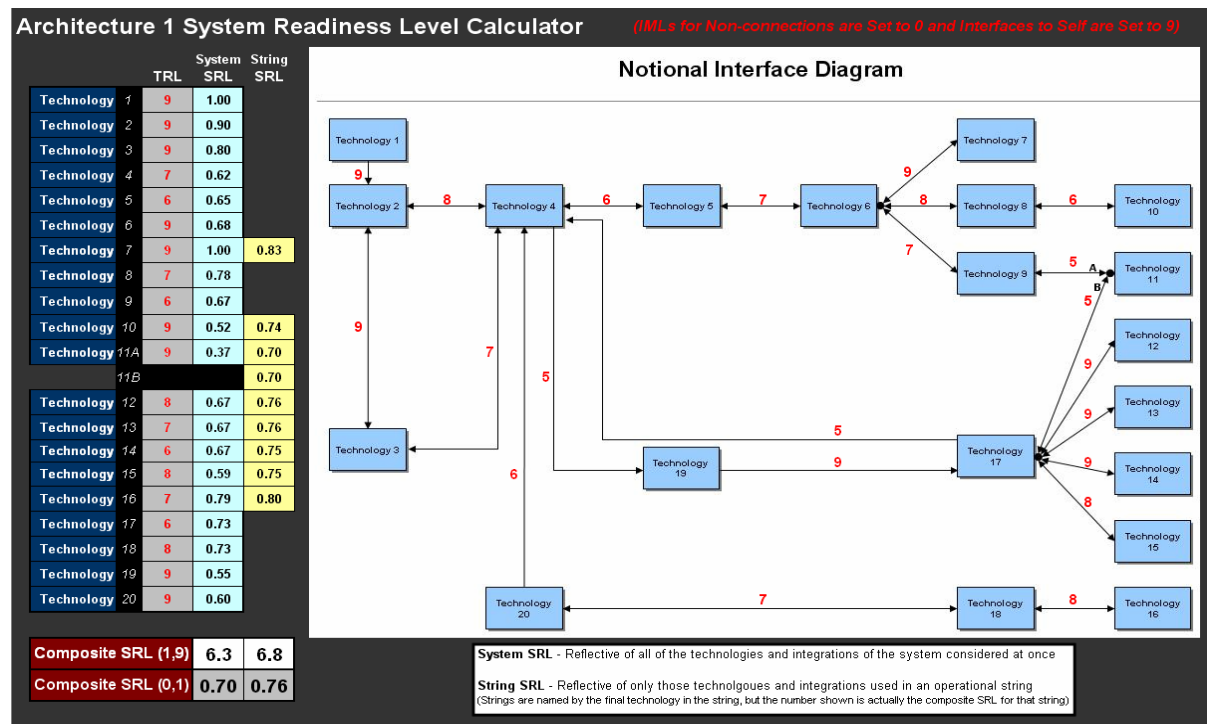

Verification and Validation Activities

IRL Criteria

- Created expanded list of IRL criteria for each readiness level
- Goal was to capture the key elements of the integration maturation process
- Presented to 30 integration SMEs from across government, academia, and industry
- Asked to assess importance of each criterion
- Results show solid buy-in among SMEs that identified criteria are key factors in successful integration

SRL Evaluation Process

- Conducted a “blind trial” of SRL methodology and evaluation process
- User’s Guide and evaluation criteria were sent to key system SMEs
- From just these resources SMEs were asked to conduct the evaluation and report on the results
- Compiled results and iterated on lessons learned to improve the process

What is an IRL?

A systematic measurement reflecting the status of an integration connecting two particular technologies

		IRL	Definition
Pragmatic		9	Integration is Mission Proven through successful mission operations.
		8	Actual integration completed and Mission Qualified through test and demonstration, in the system environment.
		7	The integration of technologies has been Verified and Validated with sufficient detail to be actionable.
Syntactic		6	The integrating technologies can Accept, Translate, and Structure Information for its intended application.
		5	There is sufficient Control between technologies necessary to establish, manage, and terminate the integration.
		4	There is sufficient detail in the Quality and Assurance of the integration between technologies.
Semantic		3	There is Compatibility (i.e. common language) between technologies to orderly and efficiently integrate and interact.
		2	There is some level of specificity to characterize the Interaction (i.e. ability to influence) between technologies through their interface.
		1	An Interface between technologies has been identified with sufficient detail to allow characterization of the relationship.

SRL Algorithm Sensitivity Evaluated

- Observed that the SRL algorithm did not take into account the varying levels of “importance” between technologies
- Examined the sensitivity of the algorithms to changes in the TRL and IRL ratings of systems with varying levels of importance
- Modified the methodology to automatically include weightings for those technologies that are most important by looking at operational “strings” or mission threads

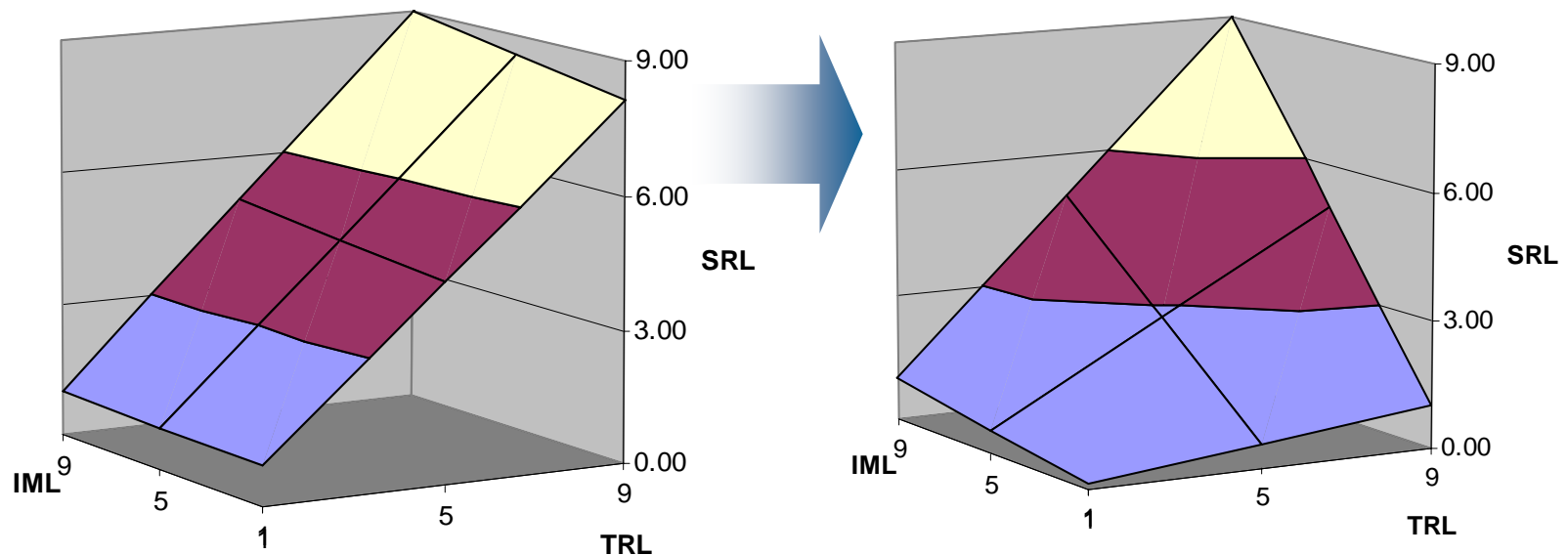

SRL Response Analysis

IML = 1

* Indicates unreasonable combination

IML = 4

Components to be integrated are selected and interfaces identified

Integration and data requirements are defined; low fidelity experimentation

TRL	Composite SRL
1	0.06
3	0.17
5	0.28
7	0.39
9	0.51*

TRL	Composite SRL
1	0.08
3	0.23
5	0.38
7	0.54
9	0.69*

IML = 7

End-to-end system integration accomplished; prototype demonstrated

IML = 9

System installed and deployed with mission proven operation

TRL	Composite SRL
1	0.10*
3	0.29*
5	0.49
7	0.68
9	0.88

TRL	Composite SRL
1	0.11*
3	0.33*
5	0.56*
7	0.78
9	1.00

Algorithms Evaluated for Sensitivity

TRL Variation Analysis

All TRLs in the system are set to 9 with the exception of the one corresponding to the system in each row, which was set to 1.

	Standard Methodology		Non-connected, Self IRLs = 0	
	Sys	String	Sys	String
MPCE 6 Connections Used by all Threads	8.6	7.9	7.9	7.2
Radar 1 Connections Used by all Threads	8.6	7.9	8.8	8.5
MH-60S 7 Connections Used by 5 Threads	8.6	8.4	7.7	8.1
COBRA 1 Connections Used by 1 Thread	8.6	8.9	8.8	8.9

NOTE: There are 9 total threads

IRL Variation Analysis

All IRLs in the system are set to 9 with the exception of the one corresponding to the link in each row, which was set to 1

	Standard Methodology		Non-connected, Self IRLs = 0	
	Sys	String	Sys	String
MPCE - CMS Used by all Threads	9.0	8.7	8.6	8.0
Radar - CMS Used by all Threads	9.0	8.7	8.6	8.0
MH-60S - MPCE Used by 5 Threads	9.0	8.8	8.6	8.4
COBRA - VTUAV Used by 1 Thread	9.0	9.0	8.6	8.9

NOTE: There are 9 total threads

Comparative Sensitivity – A look at how the algorithms penalized the SRL rating relative to one another (1 is most severe)

	Standard Methodology		Non-connected, Self IRLs = 0	
	Sys	String	Sys	String
1.) MPCE	1,4	1,2	2	1
2.) MH-60S	1,4	3	1	2
3.) Radar	1,4	1,2	3,4	3
4.) COBRA	1,4	4	3,4	4

	Standard Methodology		Non-connected, Self IRLs = 0	
	Sys	String	Sys	String
1.) MPCE - CMS	1,4	1,2	1,4	1,2
2.) MH-60S - MPCE	1,4	3	1,4	3
3.) Radar - CMS	1,4	1,2	1,4	1,2
4.) COBRA - VTUAV	1,4	4	1,4	4